

HOFMANN

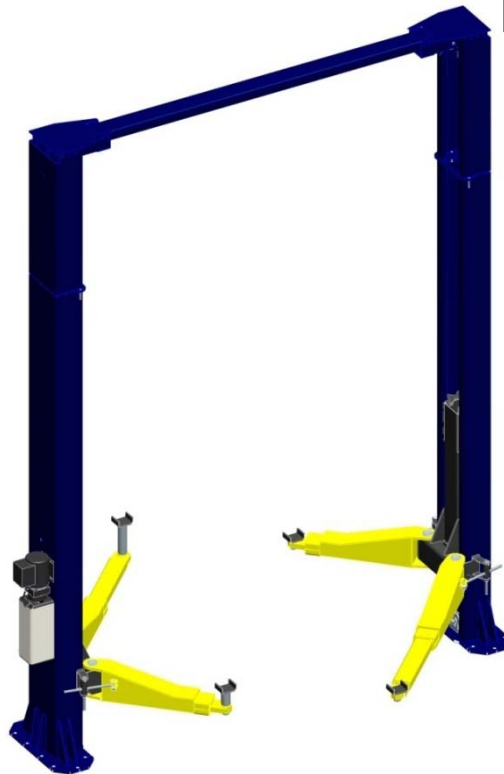

INSTALLATION and OPERATION MANUAL



DLS18016

DLS18016R

18,000 LB.
(SYMMETRICAL)

**READ THIS INSTRUCTION MANUAL THOROUGHLY
BEFORE INSTALLING, OPERATING, SERVICING OR
MAINTAINING THE LIFT.
SAVE THIS MANUAL.**

HOFMANN
USA



309 Exchange Avenue • Conway, AR 72032
(800) 251-4500 • (501) 505-2662
Fax (501) 450-2085 • www.hofmann-usa.com

HOFMANN
Canada



6500 Millcreek Drive • Mississauga, ONT L5N 2W6
(800) 267-2185
Fax (905) 821-2073 • www.hofmann.ca

MAR 2013 REV. -

6-3375

Table of Contents

1.0	GENERAL	4
1.1	OWNER/EMPLOYEE RESPONSIBILITIES	4
1.2	IMPORTANT SAFETY INSTRUCTIONS.....	5
2.0	SAFETY AWARENESS - AUTOMOTIVE LIFT INSTITUTE (ALI)	9
3.0	SPECIFICATIONS	10
3.1	Product Identification	11
4.0	CONTENT.....	11
4.1	Main Structural Components.....	11
4.2	Accessory Box.....	11
5.0	INSTALLATION REQUIREMENTS AND TOOLS	12
5.1	Foundation	12
5.2	Tools.....	12
6.0	INSTALLATION INSTRUCTION.....	13
6.1	Unpacking Procedure.....	13
6.2	Bay Layout.....	14
6.3	Tower Extension Bolting	15
6.4	Crossmember and Bracket Bolting	15
6.5	Safety Cable Pulley and Eyebolt Bracket.....	16
6.6	Stand Towers Up.....	17
6.7	Hydraulic Line Routing in Crossmember.....	18
6.8	Bolt Crossmember.....	18
6.9	Connect Hydraulic Lines.....	19
6.10	Air Valve Installation and Bulk Head Fitting.....	20
6.11	Air Line Connection	21
6.12	Install Equalizing Cables and Adjusting.....	22
6.13	Installation of Lifting Arms	24
6.14	Install Arm Restraints.....	24
6.15	Installation of Power Pack.....	25
6.16	Install Shut Off Cable.....	26
6.17	Level and Anchor Towers.....	27
6.18	Electrical Connection	30

6.19	Hydraulic System Bleeding.....	30
6.20	Additional Instructions.....	31
6.21	Final Check of Assembled Lift	32
7.0	Operating Instructions	33
7.1	Operation and Use	34
7.2	Operation Test With Vehicle.....	35
8.0	MAINTENANCE.....	36
8.1	Inspection and Maintenance Procedures.....	37
8.2	Maintenance Schedule	38
9.0	Wire Ropes Maintenance.....	39
9.1	Wire Rope Condition Guide	39
9.2	Wire Rope Replacement Criteria:	40
9.3	Wire Rope Inspection.....	41
9.4	Wire Rope Lubrication	41
9.5	Wire Rope Adjustment.....	41
10.0	LOCK OUT AND TAG OUT INSTRUCTIONS.....	42
10.1	Shut Down Procedures:	42
10.2	Isolation and Verification Procedures:.....	43
10.3	Returning to Service:.....	44
10.4	Emergency Operation:	45
11.0	Troubleshooting.....	46
12.0	Lift Assembly	47
12.1	Lift Assembly Parts List.....	48
13.0	Hydraulic System.....	50
13.1	Hydraulic System Parts List	51
13.2	Power Pack Parts List	52
14.0	Safety System.....	53
14.1	Safety System Parts List	54
15.0	Available Accessories	55

1.0 GENERAL

ATTENTION!This is a vehicle lift operation manual and no attempt is made or implied herein to instruct the user in lifting methods particular to an individual application. Rather, the contents of this manual are intended as a basis for operation and maintenance of the unit as it stands alone or as it is intended and anticipated to be used in conjunction with other equipment.

Proper application of the equipment described herein is limited to the parameters detailed in the specifications and the uses set forth in the descriptive passages. The user assumes full responsibility for any equipment damage, personal injury or alteration of the equipment described in this manual or any subsequent damages.

WARNING:Installation of equipment is hazardous. Only qualified personnel should perform installation procedures. Installers should familiarize themselves with equipment and installation procedure before attempting installation.

Decommission and disposal of product must be performed in accordance with local, state and/or federal regulations.

1.1 OWNER/EMPLOYEE RESPONSIBILITIES

1. The Owner/Employer shall ensure that lift operators are qualified and that they are trained in the safe use and operation of the lift using the manufacturer's operating instructions; ALI/SM 93-1, **ALI Lifting it Right safety manual**; ALI/ST-90 **ALI Safety Tips card**; ANSI/ALI ALOIM-2008, **American National Standard for Automotive Lifts - Safety Requirements for Operation, Inspection and Maintenance**; ALI/WL Series, **ALI Uniform Warning Label Decals/Placards**; and in the case of frame engaging lifts, ALI/LP-GUIDE, **Vehicle Lifting Points/Quick Reference Guide for Frame Engaging Lifts**.
2. The Owner/Employer shall establish procedures to periodically inspect the lift in accordance with the lift manufacturer's instructions or ANSI/ALI ALOIM-2008, **American National Standard for Automotive Lifts - Safety Requirements for Operation, Inspection and Maintenance**; and the Employer shall ensure that the lift inspectors are qualified and that they are adequately trained in the inspection of the lift.

3. The Owner/Employer shall establish procedures to periodically maintain the lift in accordance with the lift manufacturer's instructions or ANSI/ALI ALOIM-2008, **American National Standard for Automotive Lifts - Safety Requirements for Operation, Inspection and Maintenance**; and the Employer shall ensure that the lift maintenance personnel are qualified and that they are adequately trained in the maintenance of the lift.
4. The Owner/Employer shall maintain the periodic inspection and maintenance records recommended by the lift manufacturer's instructions or ANSI/ALI ALOIM-2008, **American National Standard for Automotive Lifts - Safety Requirements for Operation, Inspection and Maintenance**.
5. The Owner/Employer shall display the lift manufacturer's operating instructions; ALI/SM 93-1, ALI **Lifting it Right safety manual**; ALI/ST-90 ALI **Safety Tips card**; ANSI/ALI ALOIM-2008, **American National Standard for Automotive Lifts - Safety Requirements for Operation, Inspection and Maintenance**; ALI/WL Series, ALI **Uniform Warning Label Decals/Placards**; and in the case of frame engaging lifts, ALI/LP-GUIDE, **Vehicle Lifting Points/Quick Reference Guide for Frame Engaging Lifts** in a conspicuous location in the lift area convenient to the operator.
6. The Owner/Operator shall provide necessary lockout/tagout means for energy sources per ANSI Z244.1-1982 (R1993), **Safety Requirements for the Lockout/Tagout of Energy Sources**, before beginning any lift repairs and maintenance.
7. The Owner/Employer shall not modify the lift in any manner without the prior written consent of the manufacturer.

1.2 IMPORTANT SAFETY INSTRUCTIONS

1. **When using this lift, basic safety precautions should always be followed, including the following:**
2. Read all instructions in this manual and on the lift thoroughly before installing, operating, servicing or maintaining the lift.
3. Care must be taken as burns can occur from touching hot parts.
4. Do not operate equipment with a damaged cord or if the equipment has been dropped or damaged – until it has been examined by a qualified service person.

5. Do not let a cord hang over the edge of the table, bench, or counter or come in contact with hot manifolds or moving fan blades.
6. If an extension cord is necessary, a cord with a current rating equal to or more than that of the equipment should be used. Cords rated for less current than the equipment may overheat. Care should be taken to arrange the cord so that it will not be tripped over or pulled.
7. Always unplug equipment from electrical outlet when not in use. Never use the cord to pull the plug from the outlet. Grasp plug and pull to disconnect.
8. Let equipment cool completely before putting away. Loop cord loosely around equipment when storing.
9. To reduce the risk of fire, do not operate equipment in the vicinity of open containers of flammable liquids (gasoline).
10. Adequate ventilation should be provided when working on operating internal combustion engines.
11. Keep hair, loose clothing, fingers, and all parts of body away from moving parts.
12. To reduce the risk of electric shock, do not use on wet surfaces or expose to rain.
13. Use only as described in this manual. Use only manufacturer's recommended attachments.
14. **ALWAYS WEAR SAFETY GLASSES.** Everyday eyeglasses only have impact resistant lenses, they are not safety glasses.
15. Inspect lift daily. Do not operate if it malfunctions or problems have been encountered.
16. Never attempt to overload the lift. The manufacturer's rated capacity is shown on the identification label on the power side column. Do not override the operating controls or the warranty will be void.
17. Before driving vehicle between the towers, position the arms to the drive-through position to ensure unobstructed clearance. Do not hit or run over arms as this could damage the lift and/or vehicle.
18. Only trained and authorized personnel should operate the lift. Do not allow customers or bystanders to operate the lift or be in the lift area.
19. Position the lift support pads to contact the vehicle manufacturers recommended lifting points. Raise the lift until the pads contact the vehicle. Check pads for secure contact with the vehicle. Check all arm restraints and insure they are properly engaged. Raise the lift to the desired working height.

20. Some pickup trucks may require an optional truck adapter to clear running boards or other accessories.
21. **NOTE:** Always use all 4 arms to raise and support vehicle.
22. **Caution!** Never work under the lift unless the mechanical safety locks are engaged.
23. Note that the removal or installation of some vehicle parts may cause a critical load shift in the center of gravity and may cause the vehicle to become unstable. Refer to the vehicle manufacturer's service manual for recommended procedures.
24. Always keep the lift area free of obstruction and debris. Grease and oil spills should always be cleaned up immediately.
25. Never raise vehicle with passengers inside.
26. Before lowering check area for any obstructions.
27. Before removing the vehicle from the lift area, position the arms to the drive-thru position to prevent damage to the lift and /or vehicle.
28. **Do not** remove hydraulic fittings while under pressure.

For additional safety instructions regarding lifting, lift types, warning labels, preparing to lift, vehicle spotting, vehicle lifting, maintaining load stability, emergency procedures, vehicle lowering, lift limitations, lift maintenance, good shop practices, installation, operator training and owner/employer responsibilities, please refer to “**Lifting It Right**” (ALI/SM) and “**Safety Tips**” (ALI/ST) and vehicle lift points for service garage lifting SAE J2184.

For additional instruction on general requirements for lift operation, please refer to “**Automotive Lift-Safety Requirements For Operation, Inspection and Maintenance**” (ANSI/ALI ALOIM).

Installation shall be performed in accordance with ANSO/ALI ALIS, **Safety Requirements for Installation and Service of Automotive Lifts.**



ATTENTION! This lift is intended for indoor installation only. It is prohibited to install this product outdoors. Operating environment temperature range should be 41 – 104 °F (5 – 40 °C). Failure to adhere will result in decertification, loss of warranty, and possible damage to the equipment.

SAFETY INSTRUCTIONS

If attachments, accessories or configuration modifying components that are located in the

load path, affect operation of the lift, affect the lift electrical listing or affect intended vehicle accommodation are used on this lift and, if they are not certified for use on this lift, then the certification of this lift shall become null and void. Contact the participant for information pertaining to certified attachments, accessories or configuration modifying components.

www.autolift.org

©2007 by ALI, Inc.

ALI / WLSIA01

SAVE THESE INSTRUCTIONS

Note: Some images in this manual are generic and may not resemble the lift you have purchased.







REPLACE WORN, DAMAGED OR BROKEN PARTS WITH PARTS APPROVED BY THE ORIGINAL EQUIPMENT MANUFACTURER ONLY

2.0 SAFETY AWARENESS - AUTOMOTIVE LIFT INSTITUTE (ALI)

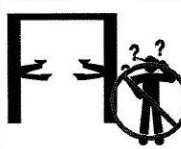
Please refer to these important instructions located on your lift.

Automotive Lift Institute, Inc WL101 Series Label Kit

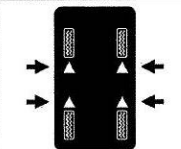
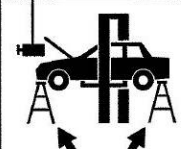
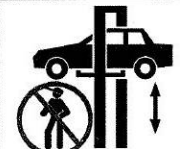
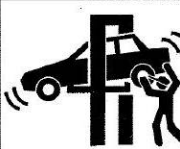
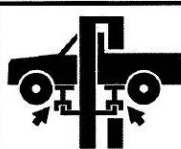
<p>NOTICE</p>  <p>Read operating and safety manuals before using lift.</p>	<p>NOTICE</p>  <p>Proper maintenance and inspection is necessary for safe operation.</p>
<p>NOTICE</p>  <p>Do not operate a damaged lift.</p>	<p>The messages and pictographs shown are generic in nature and are meant to generally represent hazards common to all automotive lifts regardless of specific style.</p> <p>Funding for the development and validation of these labels was provided by the Automotive Lift Institute, PO Box 85 Cortland, NY 13045.</p> <p>Replacement label sets may be obtained from the original lift manufacturer and ALI's member companies. They are protected by copyright.</p> <p>www.autolift.org © 2009 by ALI, Inc. ALI/WL101s</p>

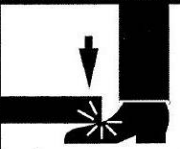
<p>CAUTION</p>  <p>Lift to be used by trained operator only.</p>	<p>CAUTION</p>  <p>Authorized personnel only in lift area.</p>	<p>WARNING</p>  <p>Clear area if vehicle is in danger of falling.</p>	<p>WARNING</p>  <p>Position vehicle with center of gravity midway between adapters.</p>
<p>CAUTION</p>  <p>Use vehicle manufacturer's lift points.</p>	<p>CAUTION</p>  <p>Always use safety stands when removing or installing heavy components.</p>	<p>WARNING</p>  <p>Remain clear of lift when raising or lowering vehicle.</p>	<p>WARNING</p>  <p>Avoid excessive rocking of vehicle while on lift.</p>
<p>CAUTION</p>  <p>Use height extenders when necessary to ensure good contact.</p>	<p>CAUTION</p>  <p>Auxiliary adapters may reduce load capacity.</p>	<p>WARNING</p>  <p>Do not override self-closing lift controls.</p>	<p>WARNING</p>  <p>Keep feet clear of lift while lowering.</p>
<p>The messages and pictographs shown are generic in nature and are meant to generally represent hazards common to all automotive lifts regardless of specific style.</p> <p>Funding for the development and validation of these labels was provided by the Automotive Lift Institute, PO Box 85 Cortland, NY 13045.</p> <p>Replacement label sets may be obtained from the original lift manufacturer and ALI's member companies. They are protected by copyright.</p> <p>www.autolift.org © 2009 by ALI, Inc. ALI/WL101s</p>		<p>The messages and pictographs shown are generic in nature and are meant to generally represent hazards common to all automotive lifts regardless of specific style.</p> <p>Funding for the development and validation of these labels was provided by the Automotive Lift Institute, PO Box 85 Cortland, NY 13045.</p> <p>Replacement label sets may be obtained from the original lift manufacturer and ALI's member companies. They are protected by copyright.</p> <p>www.autolift.org © 2009 by ALI, Inc. ALI/WL101s</p>	

3.0 SPECIFICATIONS

Capacity:	18000 lbs	8165 kg
Arm Capacity:	4500 lbs	2041 kg
Overall Width:	145-1/8"	3686 mm
Width Between Columns:	120-5/8"	3064 mm
Drive Thru Width:	108-5/8"	2760 mm
Overall Height:	193-1/8"	4905 mm
Under bar Clearance:	183"	4648 mm
Height to Lowered Lift Pads:	3-1/2"	89 mm
Height to Lift Pad (4-1/2" Adapter)	8"	203 mm
Height to Lift Pad (9-1/2" Adapter)	13"	330 mm
Retracted Arm Length:	38"	965 mm
Extended Arm Reach:	62"	1575 mm
Maximum Lifting Height (w/ 9-1/2" Adapters):	81-5/8"	2073 mm
Lifting Time:	45 Sec	
Power Rating:	208-230VAC, 23A, 1 ph, 60 Hz	
Maximum Operating Pressure @ Rated Capacity:	2848 psi	
Air Requirements:	90 - 120 psi Shop Air	

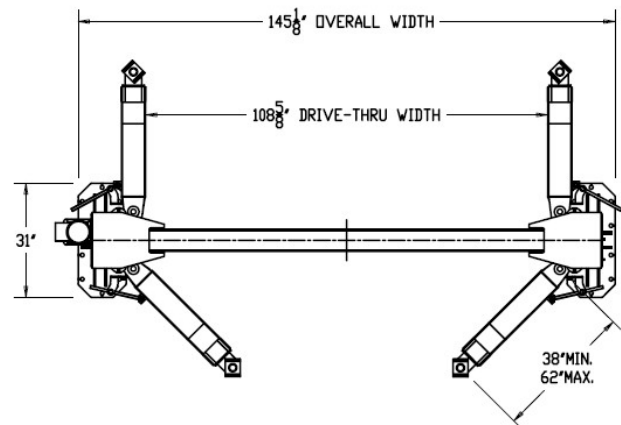
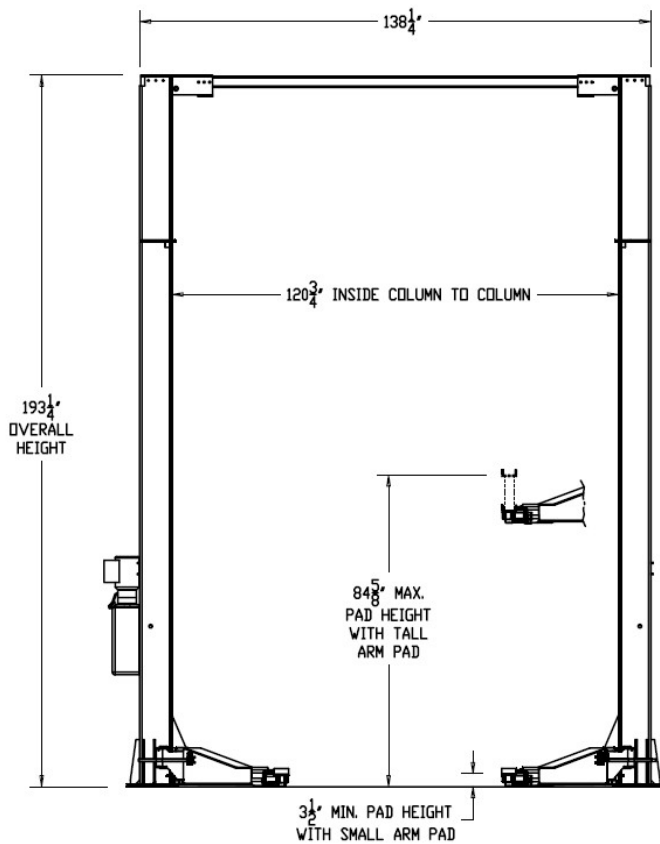

5.0 INSTALLATION REQUIREMENTS AND TOOLS

5.1 Foundation

IMPORTANT: It is the user's responsibility to provide a satisfactory installation area for the lift. Lifts should only be installed on level concrete floors with a minimum thickness of six (6) inches or 152 mm. Concrete must have a minimum strength of 4000 psi or 30 MPa and should be aged thirty (30) days prior to installation. Please consult the architect, contractor or engineer if doubt exists as to the strength and feasibility of the floor to enable proper lift installation and operation.

A qualified person should be consulted to address seismic loads and other local or state requirements.

It is the user's responsibility to provide all wiring for electrical hook-up prior to installation and to insure that the electrical installation conforms to local building codes. Where required, it is the user's responsibility to provide an electrical isolation switch located in close proximity to the lift that will enable emergency stop capability and isolate electrical power from the lift for any servicing requirements.

5.2 Tools

- a. Rotary hammer drill with $\frac{3}{4}$ " solid drill bit with carbide tip
- b. Level
- c. Hand Sledge
- d. Pry Bar
- e. Tape Measure
- f. Chalk line
- g. 12' Ladder
- h. Shortened 1 $\frac{1}{16}$ " open-end Wrench
- i. Vise Grips
- j. Snap Ring Pliers
- k. $\frac{11}{16}$ " Open End Wrench
- l. $\frac{5}{8}$ " Open End Wrench
- m. $\frac{9}{16}$ " Socket and suitable ratchet
- n. $\frac{7}{16}$ " Socket and suitable ratchet
- o. $\frac{1}{2}$ " Socket and suitable ratchet
- p. 1 $\frac{1}{8}$ " Deep Socket and suitable ratchet
- q. 4 Gal. Hydraulic fluid – Citgo A/W 46 or suitable cross-reference
- r. **Overhead crane or Forklift**
- s. Electrical Wire Fish.
- t. Wooden Blocks (For Unpacking)
- u. Screwdrivers
- v. Wherever LOCTITE symbol is shown, apply LOCTITE #242 on required fasteners. If fasteners are removed reapply LOCTITE before re-installing.



6.0 INSTALLATION INSTRUCTION

When the lift arrives on site:

- Read the owner's manual thoroughly and make sure the installation instructions are fully understood before installing, operating, servicing, or maintaining the lift.
- Check for any freight damages.
- Check the contents of the accessory and hardware boxes to make sure no parts are missing.
- Gather all the tools listed above.

6.1 Unpacking Procedure

1. Important!Place the main structural components on wooden blocks so that the steel shipping frames can be removed.
2. Remove the crossmember.
3. Remove the plastic wrapping.
4. Unbolt the steel shipping frames.
5. Lay each tower on the floor with the carriage side up.
6. Check the installation area for obstructions. (Lights, Heating Ducts, Ceiling, Floor Drains, etc.)

6.2 Bay Layout

1. Prepare the bay by selecting the location of the lift relative to the walls.
2. Clear the installation area of all packaging materials to avoid trip hazards.
3. Measure midpoint of door.
4. Using measuring tape scribe two arcs, equal distance from the midpoint.
5. The centerline of the lift occurs between the intersection of the arcs and the midpoint of the door.
6. Measure the specified distance 144" (3658 mm) to draw a second chalk line at 90° for locating the lift towers.

Note: Leave any additional room for any desired aisle or work area. Recommended minimum clearance around the lift is three feet (3ft) and above lift is four inches (4"). Ensure clearance conforms to local building and fire codes.

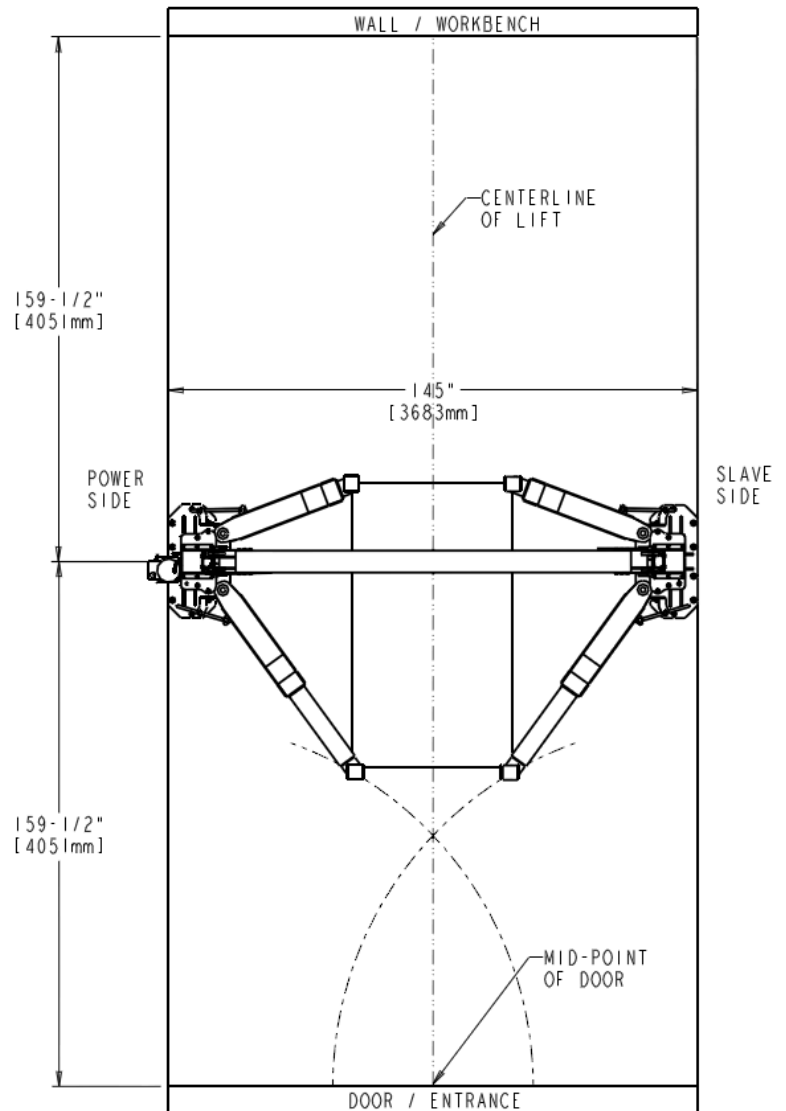

6.3 Tower Extension Bolting

1. Bolt the tower extensions on both towers using bolts from the hardware kit.

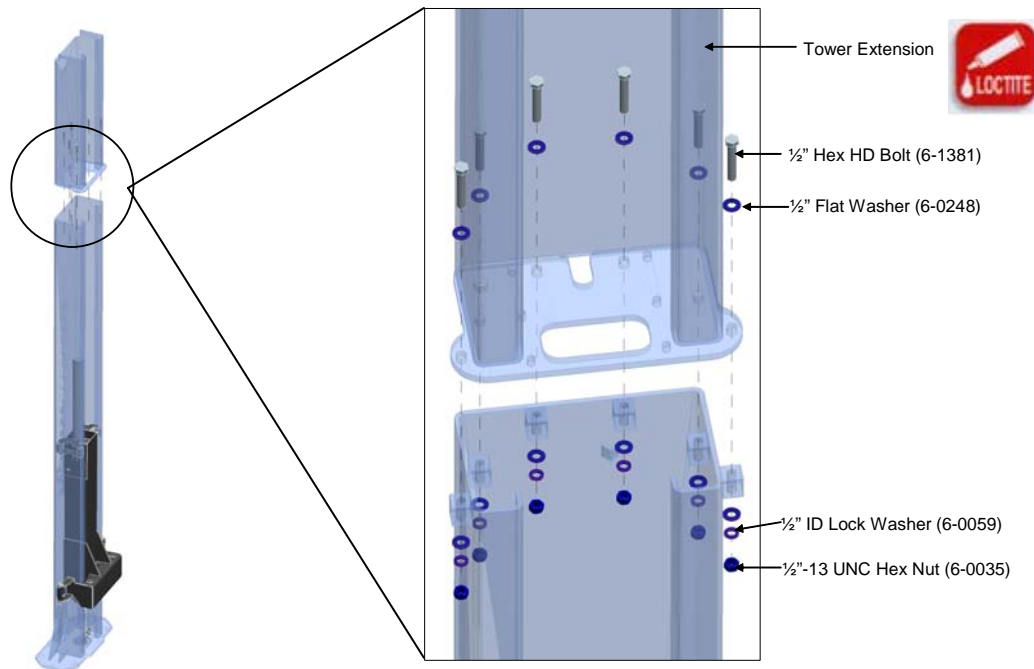

6.4 Crossmember and Bracket Bolting

1. Bolt the Crossmember and brackets to the tower extension on both towers.

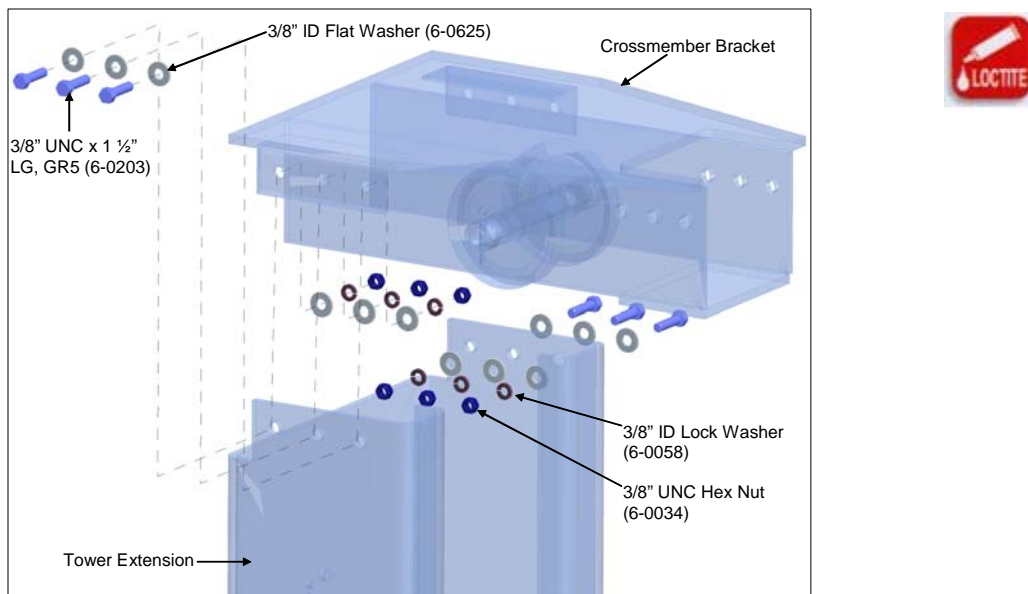

6.5 Safety Cable Pulley and Eyebolt Bracket

1. Install the Safety Cable Pulley to the Power Pack tower extension.

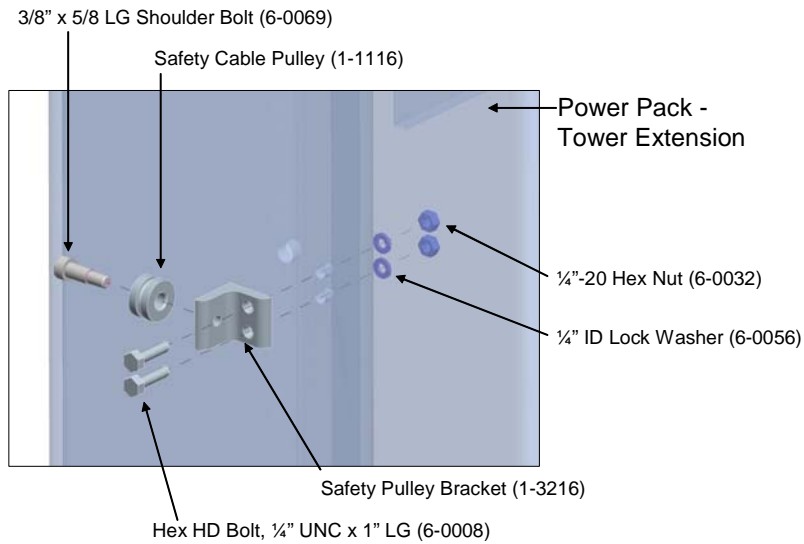

2. Install the Eye bolt to the inside of the slave side tower extension.

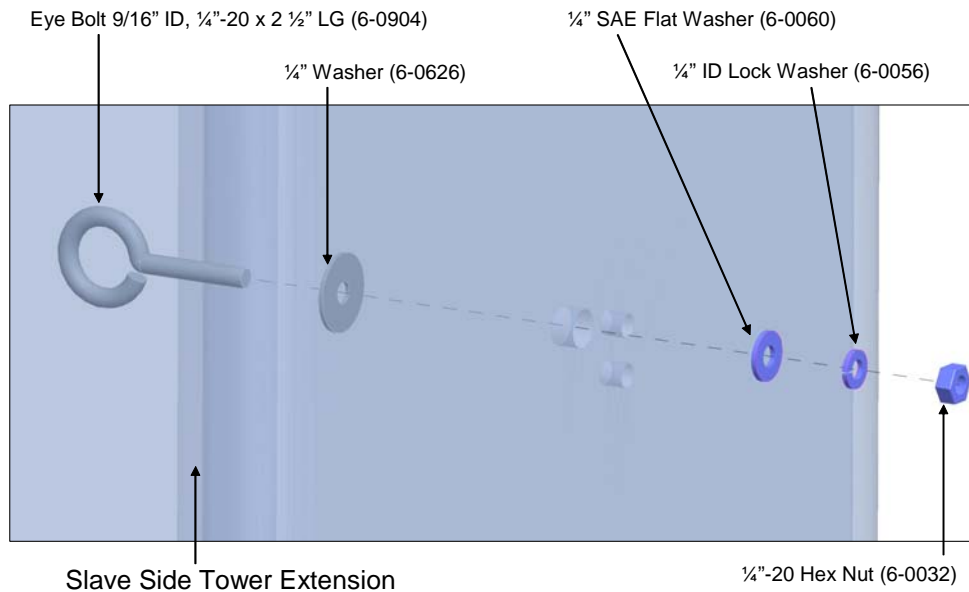

6.6 Stand Towers Up

1. Stand the towers up and position them according to the Bay Layout shown in section 6.2.

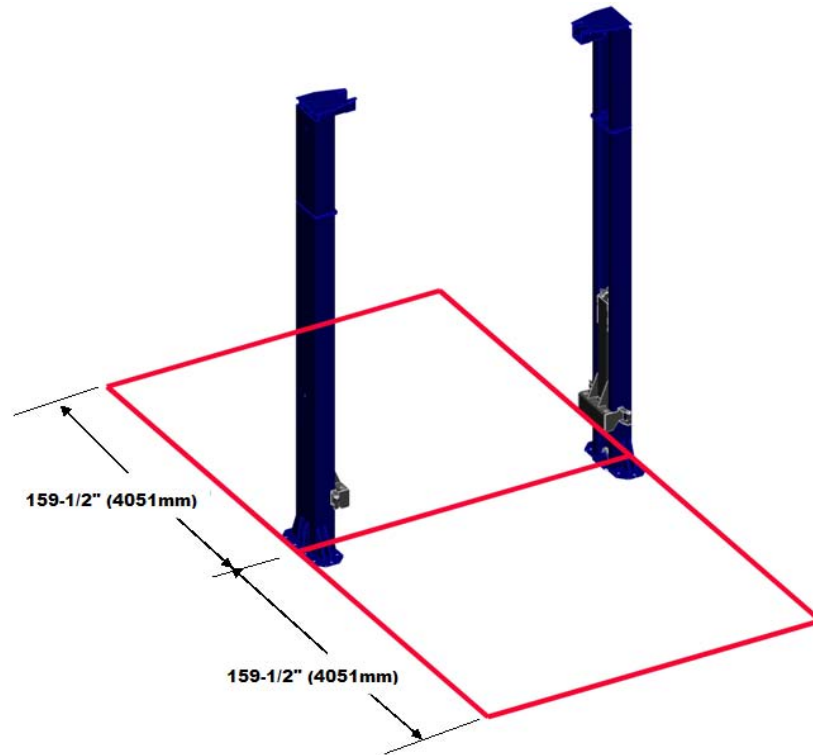

CAUTION !WHEN USING OVERHEAD CRANE OR FORKLIFT MAKE CERTAIN THAT CHAIN OR ROPE IS SECURELY FASTENED WHEN LIFTING THE TOWERS.

POSITION THE CHAIN OR ROPE SO THAT THE TOWERS DO NOT GET DAMAGED.

6.7 Hydraulic Line Routing in Crossmember

1. Assemble the Hydraulic lines for the crossmember as shown.

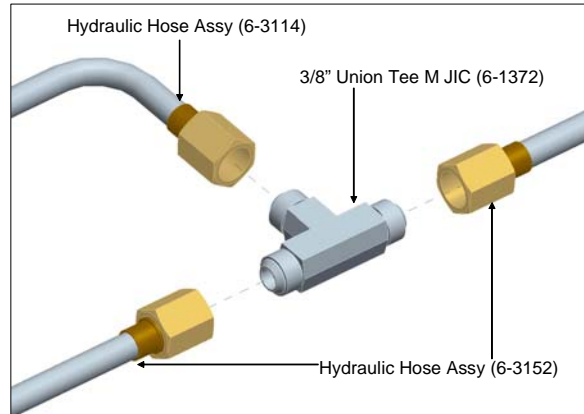

2. Insert assembled hydraulic lines through crossmember.

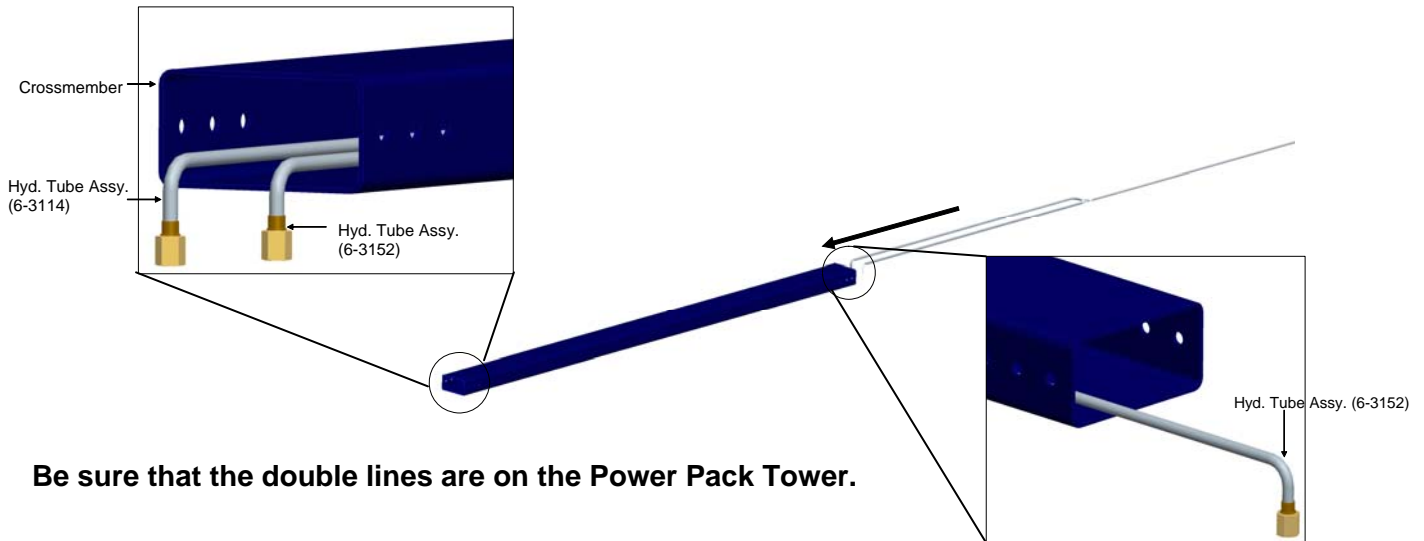

6.8 Bolt Crossmember

1. Bolt the crossmember to the brackets on both towers.

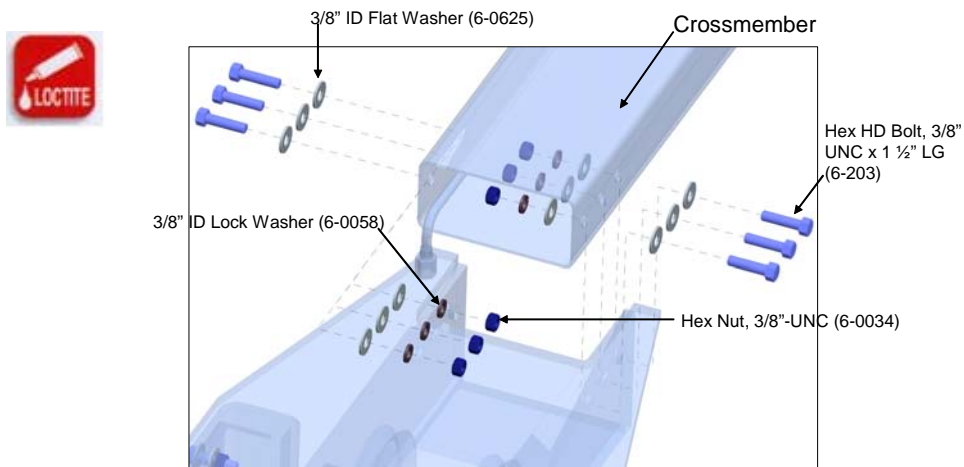

6.9 Connect Hydraulic Lines

1. Connect the tower hydraulic lines to the crossmember lines using hydraulic hose 6-3151 and 3/8" JIC Union. (tower not exactly as shown)

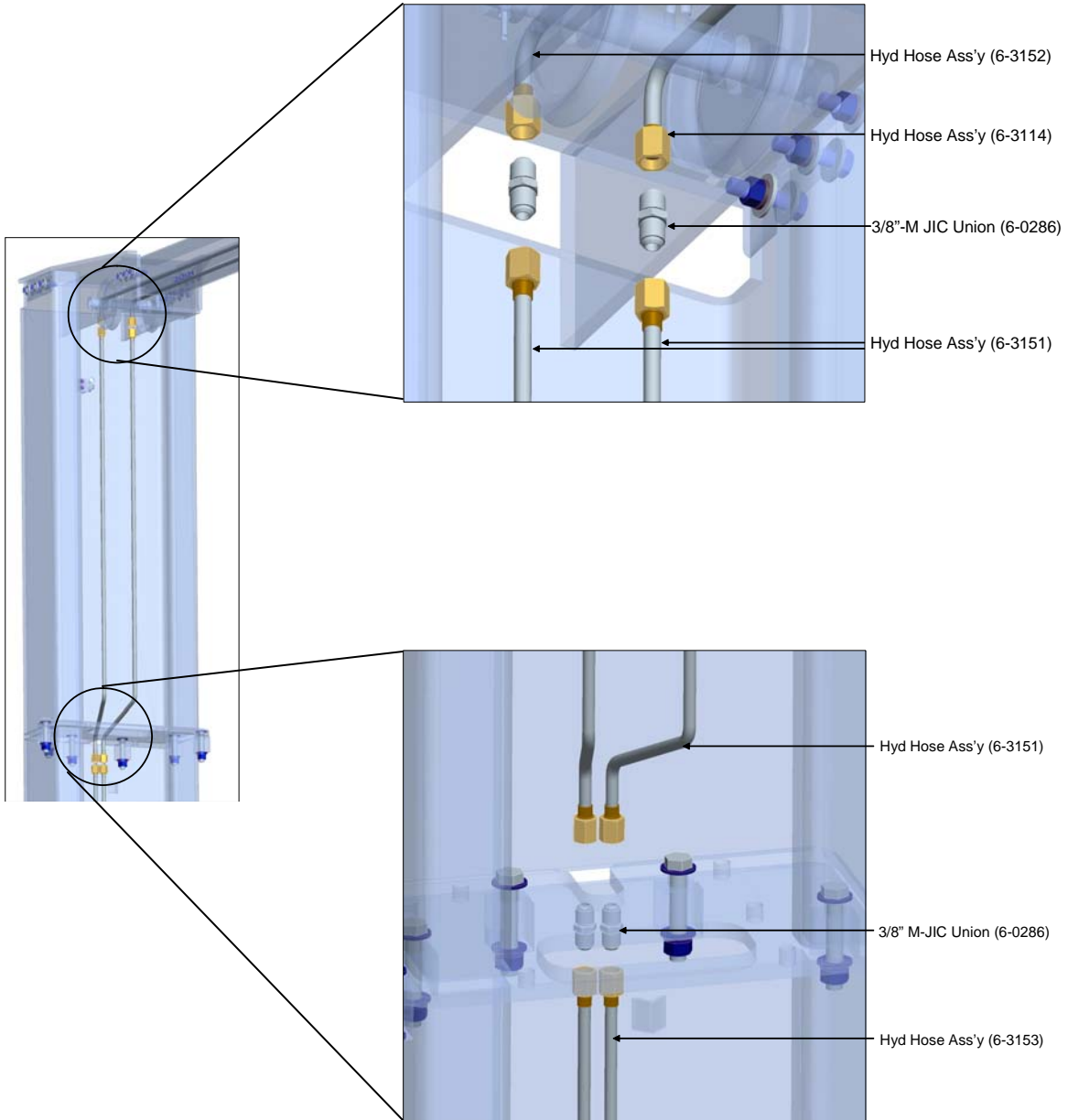

6.10 Air Valve Installation and Bulk Head Fitting

1. Remove air valve push button.

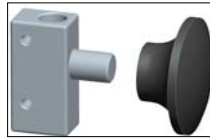

2. Attach the Tee fitting to the Air Valve.

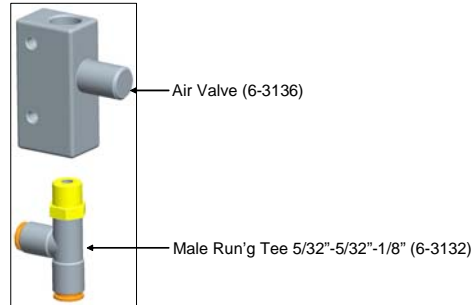

3. Insert two nuts on the Air Valve.

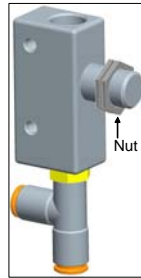

4. Attach the Air Valve assembly to the driver side tower using two more nuts provided.

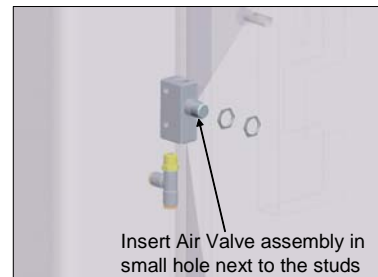

5. Screw air Valve Push button.



6. Attach the bulk head fitting to the tower extension and insert the Male pushlock fitting.

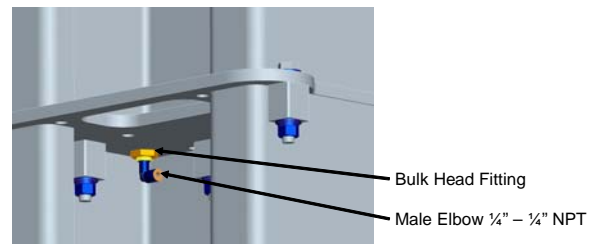

6.11 Air Line Connection

1. Uncoil the 5/32" air hose that is going to the driver side carriage and attach to the bottom of the Tee located with the Air Valve.

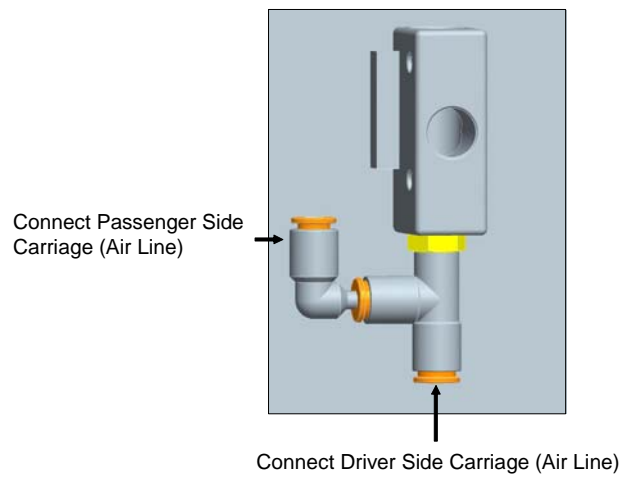

2. Feed the 5/32" air hose through the angle bracket on the tower and through the center of the tower extension.

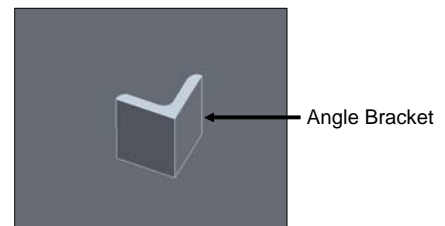

3. Fish the air hose through the crossmember to the slave tower.

4. Connect the air hose to the union located after the tower extension on the slave tower.

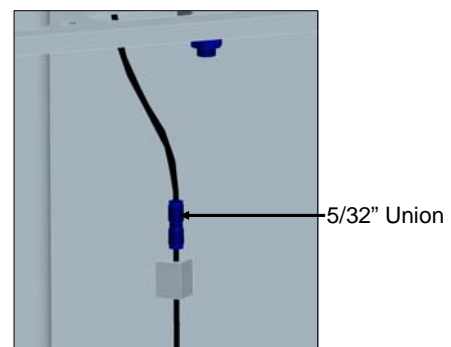

6.12 Install Equalizing Cables and Adjusting

Note: Manually lift the Carriages to a higher position until the safety latches catch, before starting this section

1. Insert the short threaded section of the cable (6-3118) through the bottom of the carriage.
2. Continue to run the cable up and out the top of the carriage.

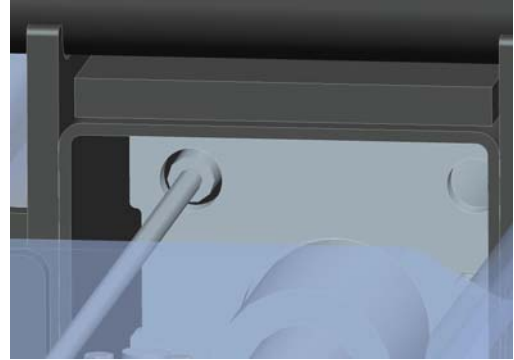

Bottom of Carriage View

3. Thread the 3/4"-10 Nylock nut **all the way** on the threaded rod.
4. Pull the cable back down to its normal position.

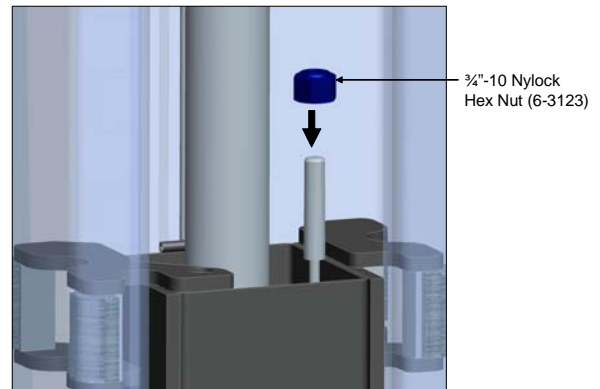

5. Remove the 2 hex bolts, keeper plate and pin. Pull out the vertical pulley at the bottom of tower.

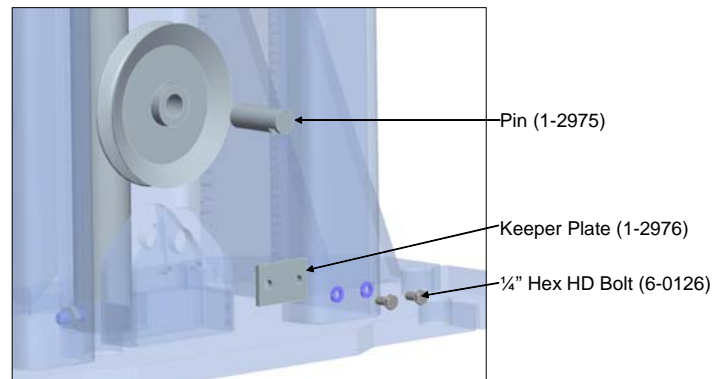

6. Pass the cable around the pulley and reassemble all the parts.

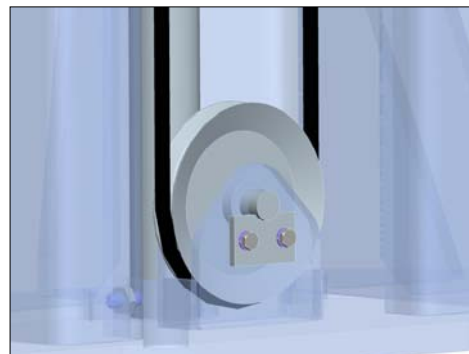

7. Route Cable as shown.

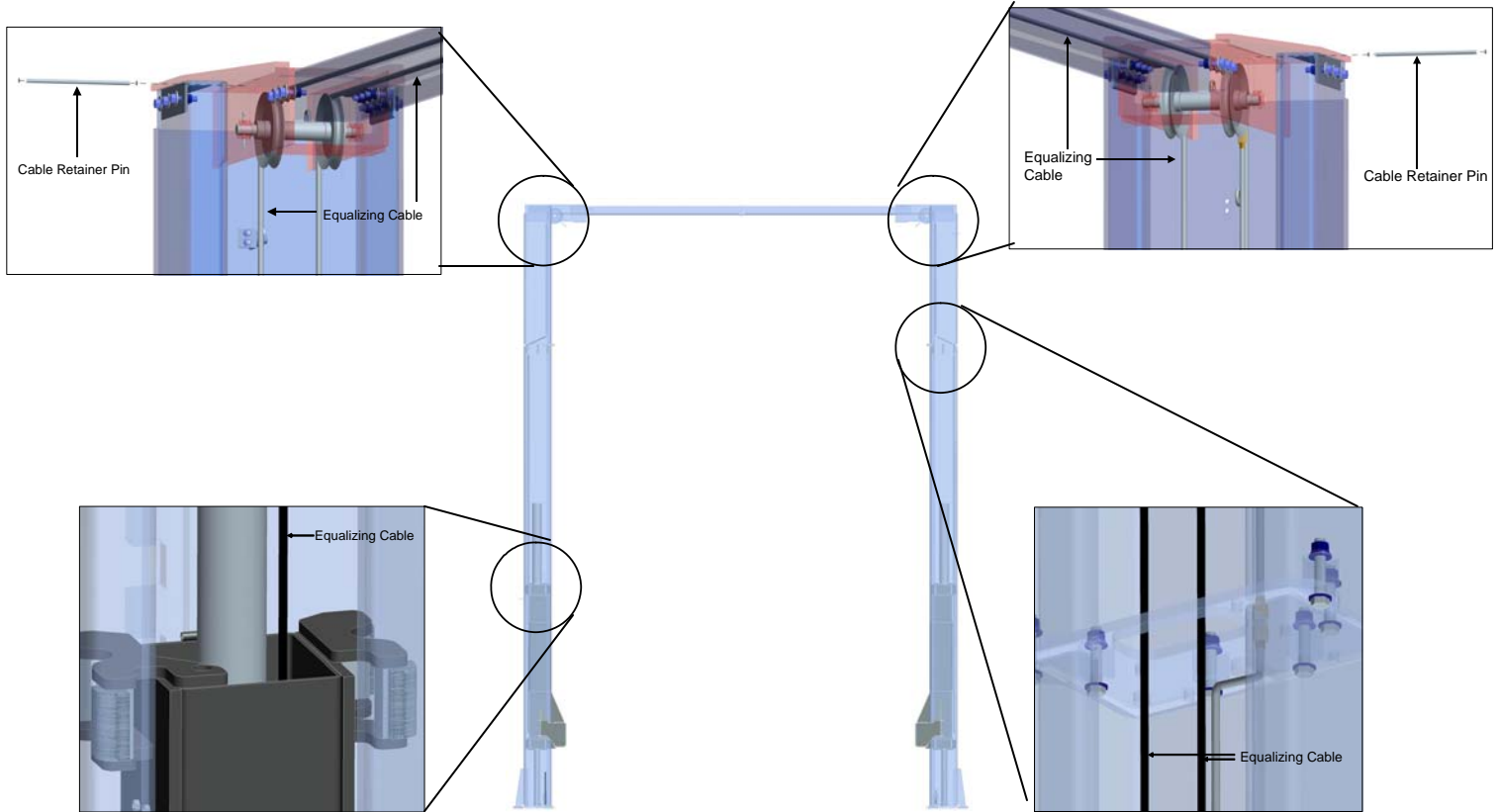

8. Insert the long threaded end of the cable through the hole at the top of the carriage.

NOTE: Only hand tighten 3/4"-10 Nylock nut at this time.

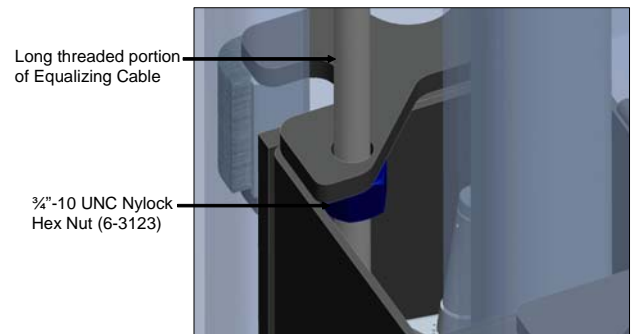

9. Repeat the above steps for the second cable.

- 10. To complete tightening of the cables, place a vise grip at least 6" above the 3/4"-10
- 11. Nylock nut on the long threaded rod and a 1 1/16" wrench on the 3/4"-10 Nylock nut.
- 12. Turn the rod with the vise grip to thread Nylock nut on rod. **Tighten each cable until approximately 1/2" deflection is present midpoint in the cable.**

NOTE: Further adjustment may be required if both safety latches do not fall in at the same time.

6.13 Installation of Lifting Arms

1. Remove the Arm pin from all four arms using snap ring pliers.

Note: Match the eye bolt bracket for the arm restraint with the brackets on the side of the carriage.

2. Install the four arms on the carriage using the arm pin and secure with the snap ring.

Note: Grease the Arm pin before installing.

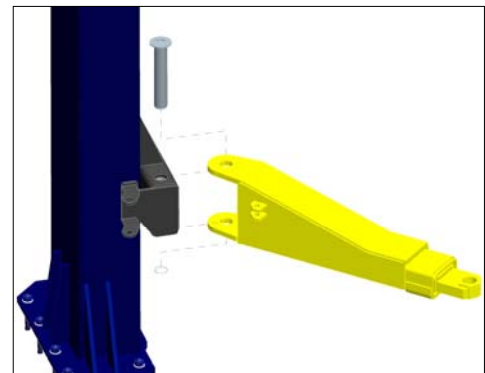
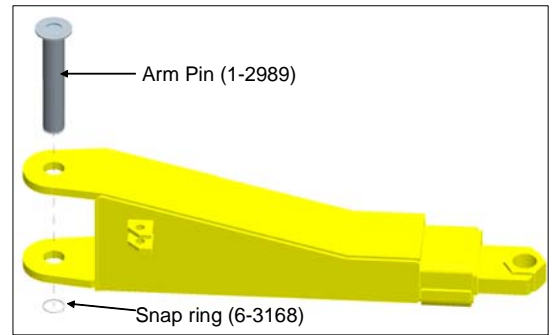

6.14 Install Arm Restraints

1. Insert the threaded eyebolt into the arm restraint device by pushing up on the armrestraint contact pin.
2. Line up the eye bolt hole with the bracket on arm and insert the 3/4" x 3" LG bolt and secure with 3/4" Nylock nut.
3. At the end of each threaded eye bolt, install the 3/4"-10 nylon lock. This will prevent the arm restraint from disengaging.

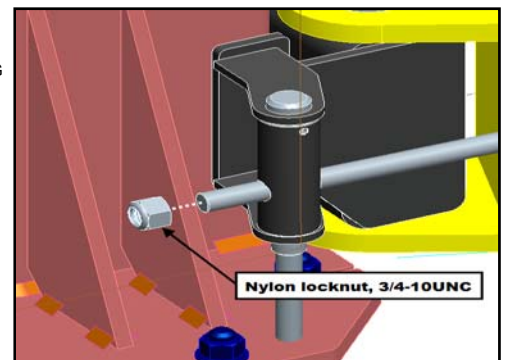
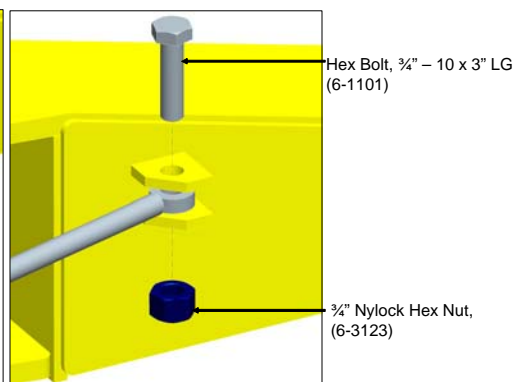
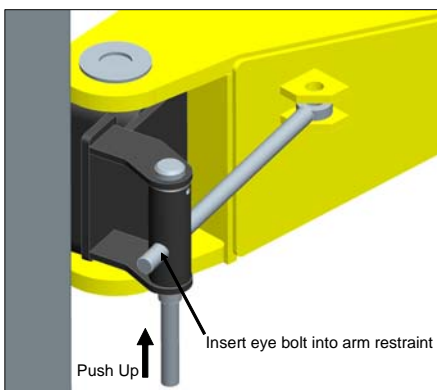

6.15 Installation of Power Pack

1. Install the Power Pack using 5/16" hardware.

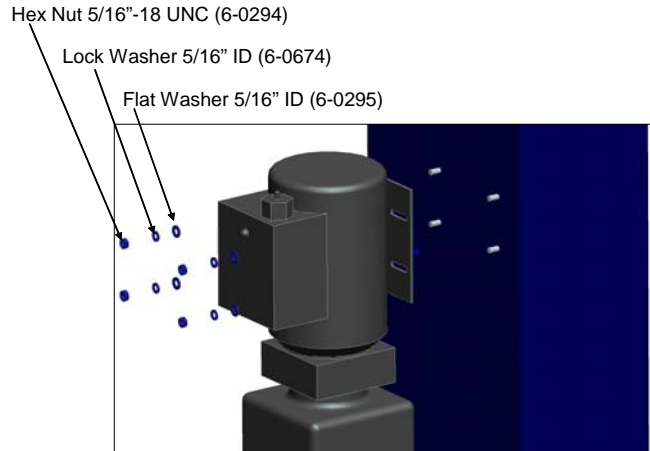

2. Install the 90 deg fitting to the power pack making sure that the opening is pointed down.

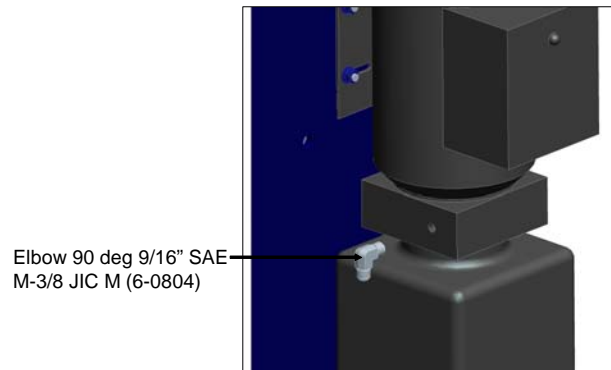

3. Connect the short flexible hydraulic hose (6-3148) from the elbow fitting on the power pack to the hydraulic hose on the tower using a 3/8" M JIC - 3/8" M JIC adaptor.

Note: Route the hydraulic hose behind the Power Pack.

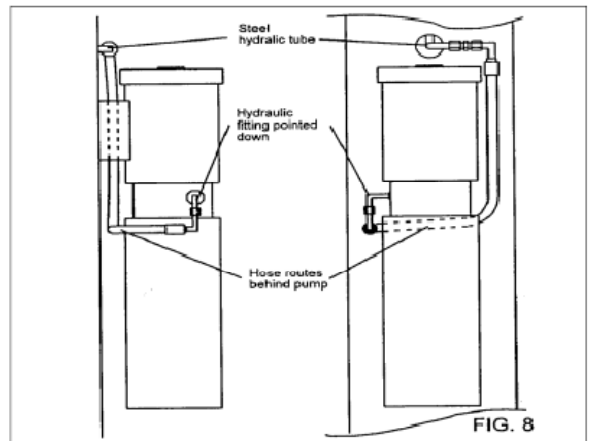

4. Remove filler cap from Power Pack and fill the reservoir with approximately 4.5 Gal. (18L) of ISO32 hydraulic oil (10 wt. hydraulic oil).

6.16 Install Shut Off Cable

1. Attach one end of the overhead shut off cable to the eye bolt on the slave tower using the 1/16" wire rope clips.

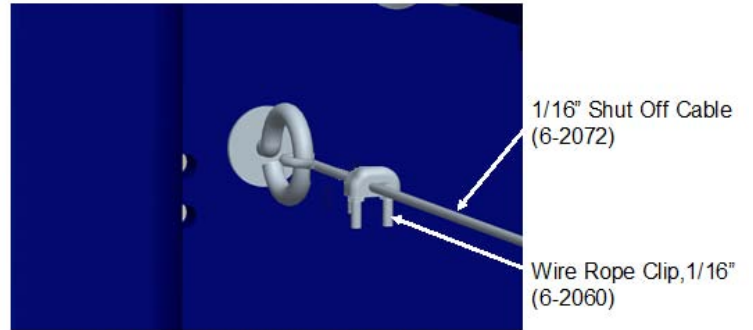

Inside view of Passenger side tower.

2. Pass the cable over the pulley on the left side tower.



Outside view of Tower

3. Fasten the overhead shut off cable to the safety limit switch activator on power unit with 1/16" wire rope clips.

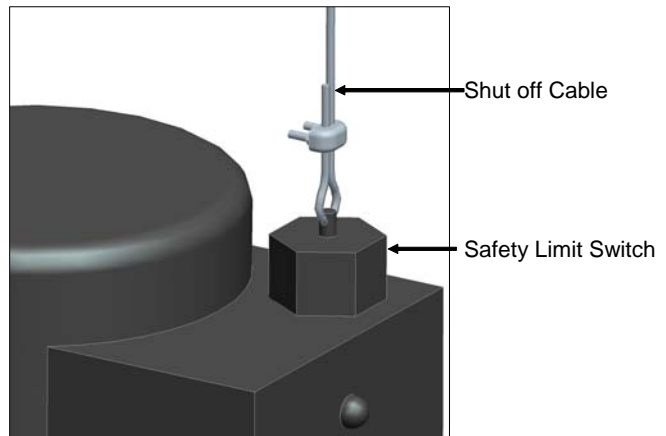

4. Adjust the tension in the cable so that there is 1/2" of deflection across the crossmember

6.17 Level and Anchor Towers



WARNING! FAILURE TO FOLLOW THESE INSTRUCTIONS MAY CAUSE AN UNSAFE OPERATING CONDITION.

1. Determine which tower is higher using a level.



2. Check if high column is level in vertical directions.

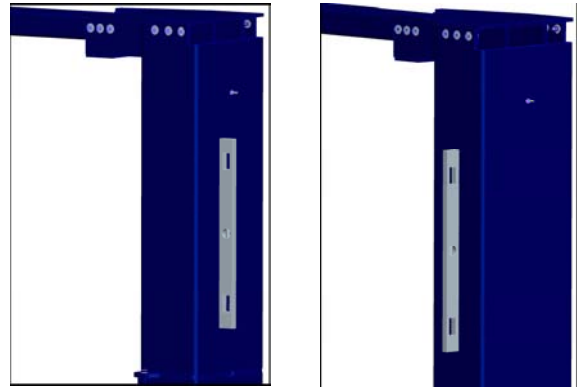

NOTE: Ensure that the base plate is completely supported by shims including near the center where it does not contact the floor.

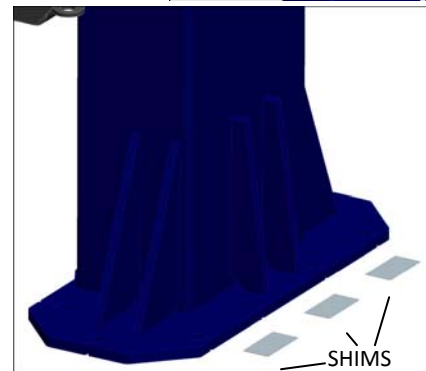

WARNING! Do not use more than $\frac{1}{2}$ " (13mm) of shims. Anchor bolts supplied allow for a maximum of $\frac{1}{2}$ " (13mm) of shim. If more than $\frac{1}{2}$ " (13mm) of shims are required, DO NOT proceed with installation and contact Product Manufacturer/Supplier for further details.

3. Refer to Bay Layout to ensure that the column is still in the proper position.

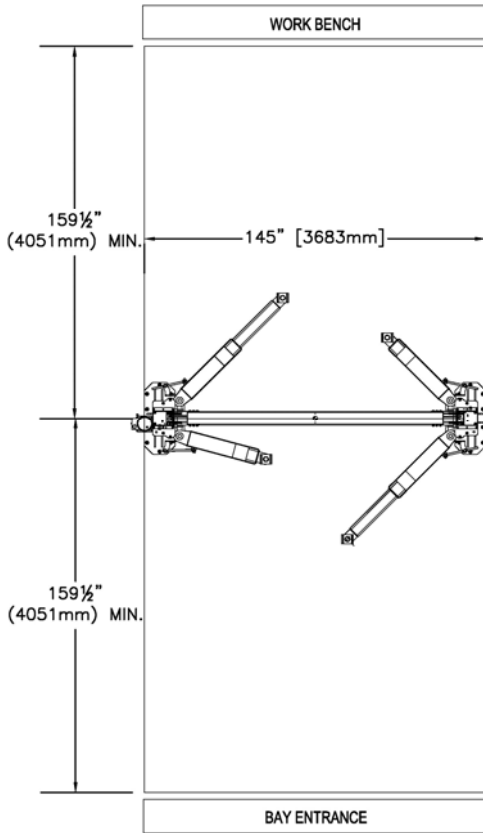

Note: Leave any additional room for any desired aisle or work area. Recommended minimum clearance around and the lift is three feet (3 ft) and above the lift is four inches (4"). Ensure clearance conforms to local building and fire codes.

4. Drill 3/4" holes using a hammer drill for the anchor bolts on the high side column.

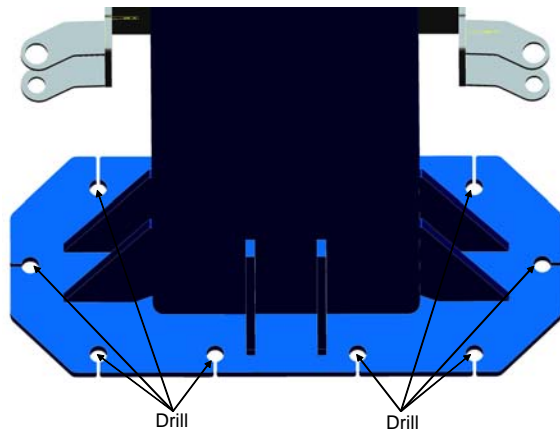

5. Clean out the drilling dust from the holes. Assemble the nut and washer onto anchors. A minimum of six threads must be visible below the surface of the nut. Hammer in the anchor bolts until they contact baseplate. **Hand tighten all anchor bolts.**

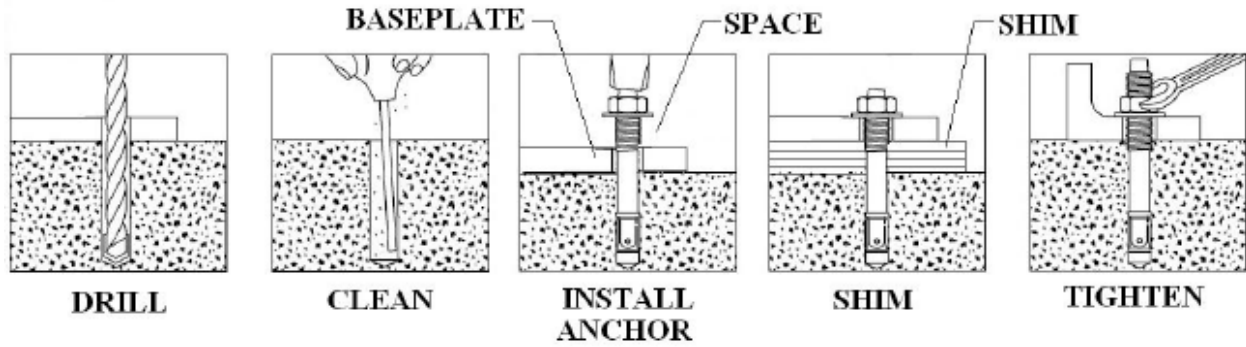

6. Check the distance from the top of the anchor to the floor. If this dimension exceeds $2\frac{1}{4}$ " due to floor slope, **DO NOT** use the supplied anchors.

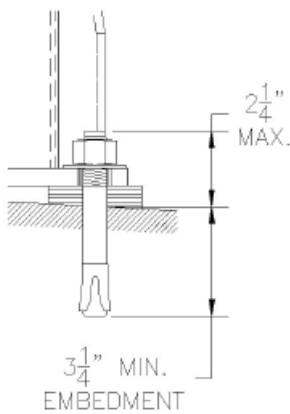

NOTE: The $\frac{3}{4}$ " x $5\frac{1}{2}$ " lg. wedge anchor bolts supplied must have a minimum embedment of $3\frac{1}{4}$ " into concrete floor.

NOTE: Check that the column is level front to rear and side to side. Adjust shims as required.

7. Torque all anchor bolts to 150 ft-lbs.(203 Nm), continually checking that the ..column is level as you proceed.

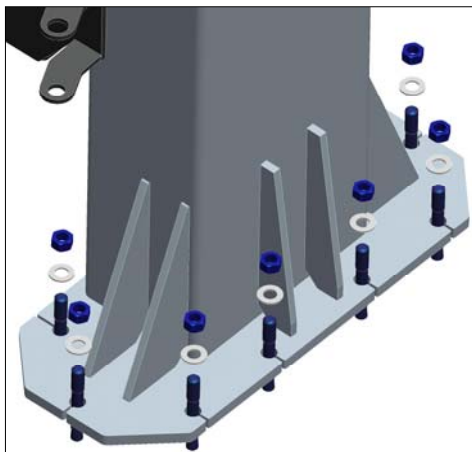

If anchor bolts do not tighten to 150 ft-lbs. OR project more than $2\frac{1}{4}$ " above the concrete surface due to floor slope, the concrete should be replaced by an appropriate concrete pad. (Consult Product Manufacturer / Supplier for further details).

8. Repeat above steps (6.12.2-6.12.7) to anchor the second tower.

6.18 Electrical Connection

1. Have a certified electrician connect the power to the lift.

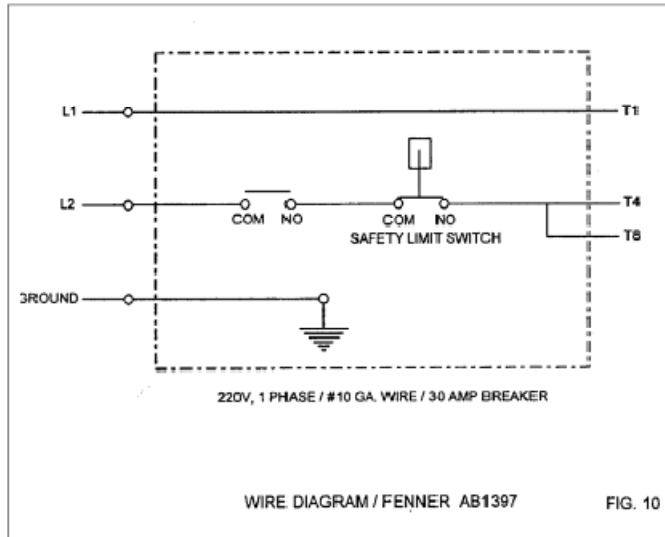

6.19 Hydraulic System Bleeding

1. Crack the caps located at the top of both cylinders.

1/4" JIC Cap (6-1884)

1/8" NPT to 1/4" NPT
(6-0280)

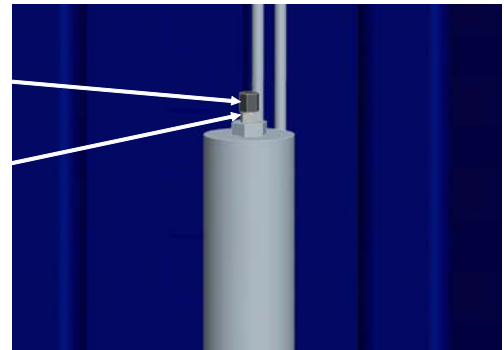

2. Power up 2"-3". You should hear air escaping around the caps. Repeat 3-4 times or until only oil is coming out of the caps.
3. Tighten the caps and lower the lift.
4. **Be sure that all other hydraulic fittings are tight.**

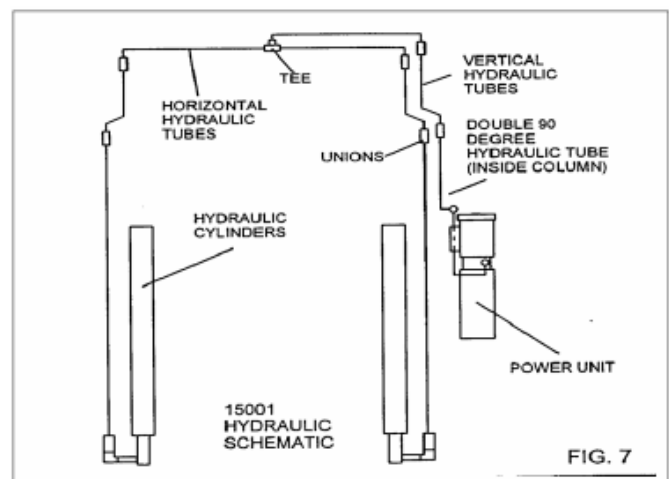

6.20 Additional Instructions

Installation shall be performed in accordance with **ANSO/ALI ALIS, Safety Requirements for Installation and Service of Automotive Lifts.**

For additional safety instructions regarding lifting, lift types, warning labels, preparing to lift, vehicle spotting, vehicle lifting, maintaining load stability, emergency procedures, vehicle lowering, lift limitations, lift maintenance, good shop practices, installation, operator training and owner/employer responsibilities, please refer to **“Lifting It Right” (ALI/SM) and “Safety Tips” (ALI/ST).**

For additional instruction on general requirements for lift operation, please refer to **“Automotive Lift-Safety Requirements For Operation, Inspection and Maintenance” (ANSI/ALI ALOIM).**

6.21 Final Check of Assembled Lift

1. Final dimension check after anchoring. _____
2. Check for air and hydraulic leaks. _____
3. Ensure cables are properly routed and free from obstructions. _____
4. Check jam nuts on cables are tightened. _____
5. Check that LOCTITE has been applied to all hardware where required _____
6. Check adjustment of safety release cable to ensure both sides working properly. _____
7. Re-check level of towers. _____
8. Check torque of anchor bolts. _____
9. Check all fasteners, tighten if necessary. _____
10. Check shut off at top of stroke to ensure lift shuts off. _____
11. Check proper operation of arm restraints. _____
12. Operate lift to full stroke then lower to ground while checking for proper functionality. _____
13. Ensure Customer Care Kit is complete and given to operator.
 - a. Operation Manual _____
 - b. ANSI / ALI Lift It Right Manual _____
 - c. ANSI / ALI Safety Tip Card _____
 - d. ANSI / ALI ALIS Safety Requirements for Installation and Service of Automotive Lifts _____
 - e. ANSI / ALI Quick Reference Guide _____
14. Train end user on operation of lift. _____

7.0 OPERATING INSTRUCTIONS

Read and understand all safety and operation labels on the lift. Refer to the "**Lifting it Right**" manual and "**Safety Tips**" card supplied to you for additional important instructions and information.

NOTE: Some vehicles may have the manufacturer's Service Garage Lift Point locations identified by triangle shape marks on its undercarriage (reference SAE J2184). Also, there may be a label located on the right front door lock face showing specific vehicle lift points. If the specific vehicle lift points are not identified, refer to the "Typical Lift Points" figure below or the ANSI/ALI **Lift Point Guide** included with your lift.

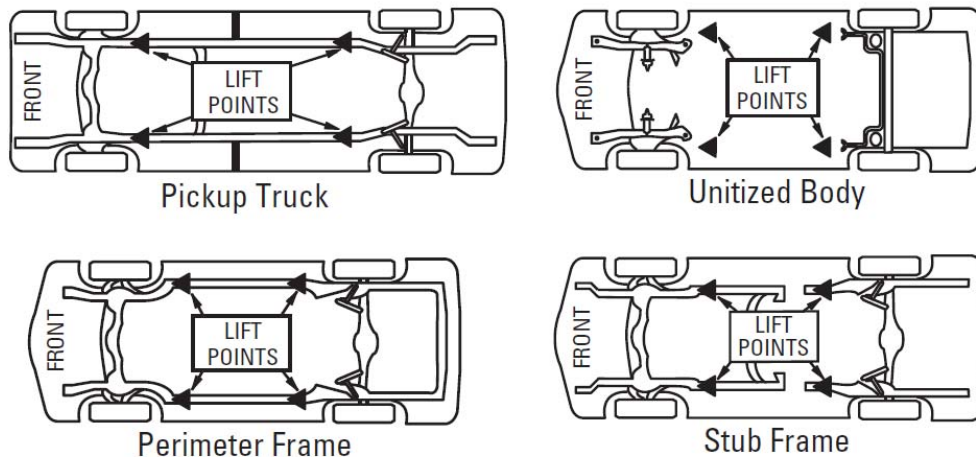

1. Position arms to drive-thru position.
2. Refer to supplied literature prior to loading vehicle. Center the vehicle between the lift posts.
3. Only lift the vehicle on the manufacturers recommended lift points. Refer to supplied lift points guide (reference ANSI/SAE J2184-1992).
4. Locate lift pads on auto manufacturer's recommended lift points. Once you have correctly positioned the lift arms, ensure that all arm restraints are properly engaged.
5. Raise the vehicle by pushing the "UP" button on the powerpack until the vehicle's suspension has left the ground.
6. Inspect to make sure there is no interference with any objects and for proper engagement of the lifting pads.
7. Shake vehicle moderately by pushing on either the front or rear bumper. Visually inspect the lifting pads again. If the vehicle starts slipping on the lifting pads, or otherwise appears unstable on the lift, you have positioned the swing arms and adapters incorrectly. Carefully lower the lift and start over.

8. When satisfied, continue lift the vehicle to the desired working height, lower onto the mechanical safety using the lowering lever.
9. Once vehicle is ready to be removed, raise lift so that the mechanical safety can be released. Pull down and hold the mechanical safety release lever, then press the hydraulic lowering lever until the lift has fully collapsed to the grounds and the arm restraints are disengaged.
10. Swing the lift arms to the drive-thru position prior to moving the vehicle.

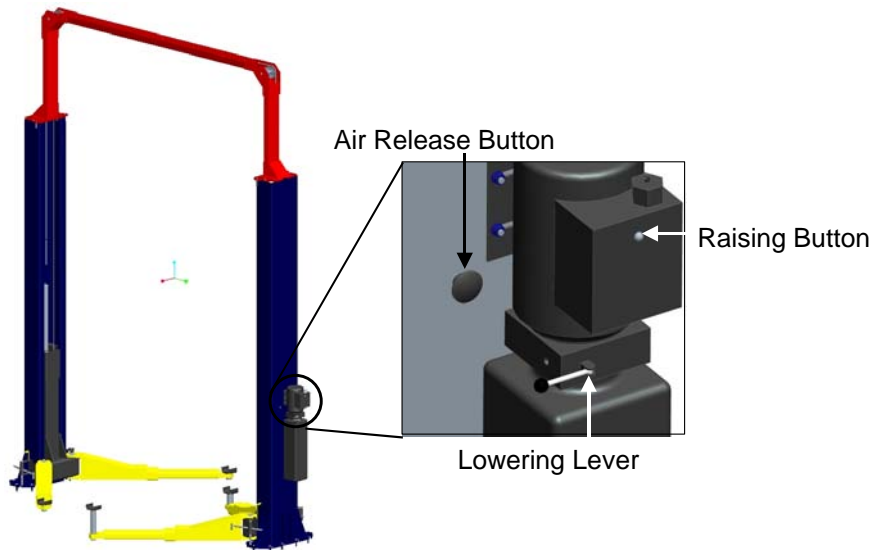

7.1 Operation and Use

Caution



1. Do not exceed maximum rated lift capacity.
2. Only trained and authorized personnel should operate this lift. Read, understand and follow all literature supplied with the lift.
3. Make certain lift area is clear of all personnel during lift operations.
4. Always watch the lift during operation.

SPECIAL INSTRUCTIONS for long wheelbase vehicles such as limousines, cargo vans, light trucks with toolboxes, extended and dual cab light trucks, etc.

1. Do not lift without finding the vehicles center of gravity.
2. Do not exceed the stated capacity of the lift.
3. Do not operate the lift if the load is not stable.

4. Observe overhead clearance for obstructions when lifting light trucks with ladder racks, cranes, campers, etc.
5. Always use all four arms when lifting a vehicle and follow the vehicle manufacturer's guidelines for recommended lifting points.
6. Height extenders may be needed for proper frame engagement when lifting light trucks and vans.
7. Do not use wood, bricks, homemade extenders, etc.

7.2 Operation Test With Vehicle

1. Lower lift to the ground. _____
2. Drive vehicle on to lift and locate the arms as per the "Lift it Right" manual. _____
3. Raise lift to and lower onto 3-4 lock positions during full rise to ensure all locks are working correctly. _____
4. Re-adjust cables if necessary while vehicle is on. _____
5. Check lowering speed and smooth decent rate. _____
6. Lower lift to the ground and drive vehicle off lift. _____

If any problems occur during the final checkout or operation of the lift please contact customer service at 1-800-225-5786.

8.0 MAINTENANCE



Only trained personnel who are familiar with the equipment should be allowed to service the lift.



All Maintenance other than the routine tasks outlined below must be carried out by the manufacturer/supplier.



Before starting any maintenance or repairs to the lift make sure the main power switch is locked.

Guidelines to be followed for proper lift maintenance include:

Always use genuine spare parts.

Always use tools and equipment suitable for the work to be carried out.

Follow the scheduled maintenance and check periods shown in this manual.

Refer to manufacturer's documentation:

Exploded views for ordering of replacement parts.

The trouble shooting guide contained in this manual.

CAUTION! Always check for floor cracks emanating from under the columns, structural wear or if the lift is visually out of plumb. Contact the manufacturer for assistance.

8.1 Inspection and Maintenance Procedures

The schedule is based on conditions found in the usual automotive service environment under normal usage (approximately 1200 cycles per year). In cases of high volume operation or areas with a high density of airborne debris, the schedule must be accelerated.

DAILY:

1. Check all hydraulic lines and fittings for pinch points, damage, cracks or leaks.
2. Check all electrical wiring for pinch points, cracks or damage.
3. Check all moving parts for uneven or excessive wear.
4. Repair or replace all damaged, defective, worn or broken components immediately.
5. Check the telescopic arms for movement. Clean any grease or oil from the lifting adapters.
6. Raise and lower the lift at the beginning of each shift (without a vehicle on) to verify the lift is leveled and operating properly.

EVERY TWO MONTHS:

1. Check the arm restraint rods. Be sure to keep threads clean and rust free.
2. Clean and re-grease slide block channels inside of both columns.
3. Grease arm pins.

EVERY FOUR MONTHS:

1. Column anchor bolts and re-torque to 150 ft. lbs if required. If unable to tighten suspend use of lift and contact manufacturer.
2. Lubricate cable pulleys.
3. Check equalizing cable adjustment. (see section 6.1)

EVERY SIX MONTHS:

1. Inspect carriage bearings, grease with lithium RP #2. Replace bearings when clearance between bearing mounting plates and column is less than 1/16".

EVERY YEAR:

1. Inspect lift as per Automotive Lift Operation, Inspection and Maintenance (ALOIM).

EVERY TWO YEARS:

1. Change hydraulic fluid with CITGO AW 46 or equal.

9.0 WIRE ROPES MAINTENANCE

⚠ WARNING

- Wire ropes are critical to safe and reliable performance of your lift.
- Cables are expendable items and should be replaced as a set.

9.1 Wire Rope Condition Guide

Typical good cable

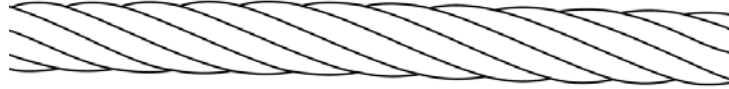

Cable with necking



Broken wires

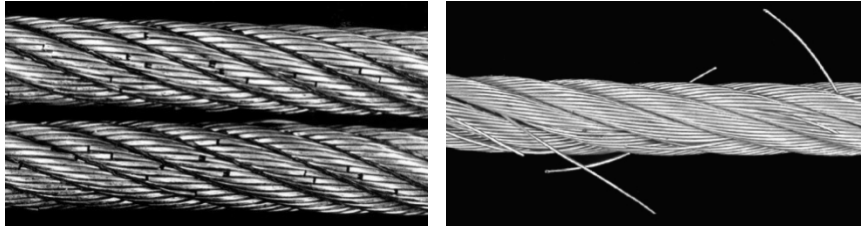

Excessive wear of wires

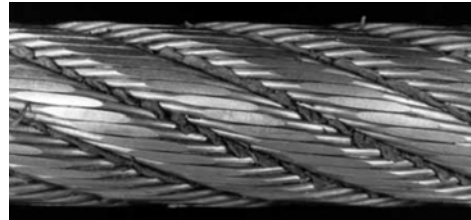

Rust on sheave stack and ropes



Corrugated sheave groove



(Pictures above are of a 4-Post Lift, conditions still apply to 2-Post Lifts)

9.2 Wire Rope Replacement Criteria:

⚠ WARNING

If any cable is found to be in need of replacement, the entire cable set, pulleys and safety rollers must be replaced immediately.

See Section: [8.2 Wire Rope Condition Guide](#)

In the following table, "lay" means the distance measured along a line parallel to the axis of the rope in which the strand makes one complete turn about the axis of the rope, or the wires make a complete turn about the axis of the strand.

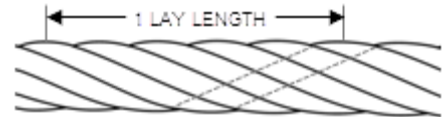

<i>The wire rope must be removed from service if one or more of the following criteria are met:</i>
1. More than six randomly distributed broken wires in one rope lay or 6×d length.
2. More than three broken wires in one strand in one rope lay or 6×d length.
3. Three or more broken wires at rope terminations.
4. One outer wire broken at the point of contact with the core of the rope which has worked its way out of the rope structure and protrudes or loops out from the rope structure
5. Heavy rusting, corrosion, or pitting. A light surface corrosion on outer wires is normal.
6. Wear or scraping of one-third of the original diameter of outside individual wires
7. Excessive stretch. It is normal for new cable to require adjustment during "break-in", after which small periodic adjustments may be required. However, if a cable that has been in service for 6 months should suddenly require frequent adjustments or has used all the cable adjustment available, all cables must be replaced immediately.
8. Deformed strands, kinking, crushing, bird-caging, or any other damage or distortion of wire rope structure
9. Variations in diameter (necking) or any change from normal appearance
10. Reductions from nominal diameter of more than 1/32" (for cables 3/8" to 1/2" dia. inclusive)
11. End attachments cracked, deformed or worn

9.3 Wire Rope Inspection

Inspect wire rope cables for wear or damage. Wipe cables with a rag to detect hard to see small broken or frayed cable strands. See chapter **8.2**, and ANSI/ALI ALOIM standard.

9.4 Wire Rope Lubrication

Lubricate wire ropes with lift in both lowered and raised position, by spraying them with wire rope lubricant (i.e. 2001 MONOLEC®) and wiping the cable down.

9.5 Wire Rope Adjustment

Adjust cables if lifting is uneven or lift is not level (See chapter 7.15.3). Never make adjustments with weight on lift. If running out of adjustment threads, cables need to be replaced. Do not add washers or other spacers to re-use previously used adjustment threads.

NOTE: Wire rope tension adjustment should be performed when installing the lift and every three months.

10.0 LOCK OUT AND TAG OUT INSTRUCTIONS

IMPORTANT: This machine does not have integral devices that will isolate the electrical, pneumatic, stored and hydraulic energy source. Appropriate isolation or blocking devices must be used that have the provisions to be switched in the off position and locked in that position.

ALL MAINTANANCE AND SERVICE MUST BE PERFORMED BY A QUALIFIED PERSON.

ALL MAINTANANCE AND SERVICE MUST BE PERFORMED WITH THE LIFT UNLOADED.

IT IS THE SHOP OWNERS RESPONSIBILITY TO ENSURE ENERGY ISOLATING DEVICES ARE:

- **Accessible**
- **Conveniently located to facilitate the application of lockout devices during service and maintenance**
- **Located outside any hazardous area.**
- **At a convenient manipulating height (i.e. not overhead, on ladders or under machinery)**
- **Adequately labeled or marked. Identification shall include machine ID, energy type and magnitude.**
- **Capable of being locked or otherwise secured in an effective isolating position.**

Effective hazardous energy control procedures will protect employees during machine and equipment servicing and maintenance where the unexpected energization, start up or release of stored energy could occur and cause injury, as well as while working on or near exposed de-energized electrical conductors and parts of electrical equipment. Hazards being guard against include being caught in, being crushed by, being struck by, being thrown from, or contacting live electrical circuits/parts.

In preparation for lockout, an initial survey must be made to locate and identify all energy isolating devices to be certain which switch, valve, or other energy isolating devices apply to the machine / equipment to be locked out. More than one energy source (electrical, hydraulic, pneumatic, or others) may be involved.

10.1 Shut Down Procedures:

- **Notify all affected employees that a lockout or tagout system is going to be utilized and the reason for. The authorized employee shall know the type and magnitude of energy that the lift utilizes and shall understand the associated hazards.**

- **ELECTRICAL:** Located at the user control panel, press the “E-STOP” button to disconnect the raise and lower functions.



ELECTRICAL ENERGY IS STILL PRESENT AT THE LIFTS ELECTRICAL PANEL WHEN THE EMERGENCY STOP BUTTON IS PRESSED. ELECTRICAL ENERGY MUST BE TURNED OFF AND ISOLATED AT THE DISCONNECT PANEL PRIOR TO PERFORMING SERVICE OR MAINTANANCE ON THE LIFT.

10.2 Isolation and Verification Procedures:

ENERGY TYPE AND SOURCE	LOCKOUT LOCATION (TO BE COMPLETED BY END USER)	PROCEDURE FOR LOCING OUT AND OR RELEASING ENERGIES	VERIFY PROCEDURES
<p>STORED ENERGY</p> <p>AND</p> <p>HYDRAULIC PRESSURE 3000-5000 PSI</p>		<p>LOWER THE LIFT TO ITS LOWEST REST POSTION. IF THE LIFT MUST BE SERVICED OR MAINTAINED IN THE RAISED POSITION, ENSURE THAT THE LIFT IS PLACED ON THE MECHANICAL LOCKS.</p> <p>FOR SCISSOR LIFTS, ADDITIONAL SUPPORT WITH SUPPLEMENTARY JACK STANDS, BLOCK AT THE SLIDERS AND A COME ALONG SECURED BETWEEN THE SCISSORS.</p> <p>FOR 4-POST LIFTS, ADDITIONAL SUPPORT WITH SUPPLEMENTARY JACK STANDS.</p>	<p>VERIFY THAT THE LIFT IS (IF APPLICABLE):</p> <p>CONTACTING THE MECHANICAL LOCKS,</p> <p>RESTING ON THE SUPPLEMENTARY JACK STANDS,</p> <p>BLOCKS ARE SECURLY PLACED</p> <p>COME ALONG IS SECURED BETWEEN THE SCISSORS.</p>

<p>ELECTRICAL 240VOLTS</p>		<p>AT THE LIFT, PRESS THE EMERGENCY STOP BUTTON COMPLETELY TO DE-ENERGIZE THE CONTROL BUTTONS (IF APPLICABLE).</p> <p>AT THE DISCONNECT PANEL, PLACE THE DISCONNECT HANDLE IN OFF POSITION. ATTACH A MULTIPLE LOCKOUT DEVICE. LOCK AND TAG.</p> <p><u>DANGER: LINE SIDE OF DISCONNECT REMAINS ENERGIZED</u></p>	<p>ATEMPT TO RESTART THE SYSTEM, THE SYSTEM MUST NOT START. VISUALLY VERIFY OPEN DISCONNECTS AND LOCKING DEVICE INSTALLED.</p>
<p>PNEUMATIC UPTO 160PSI</p>		<p>SLOWLY CLOSE LOCKOUT VALVE TO RELEASE AIR PRESSURE GRADUALLY. ATTACH MULTIPLE LOCKOUT DEVICE, LOCK AND TAG.</p> <p><u>DANGER: LINE SIDE OF DISCONNECT REMAINS PRESSURIZED</u></p>	<p>VERIFY THE VALVE IS CLOSED AND LOCKOUT DEVICE IS PROPERLY ATTACHED. OPERATE THE PNEUMATIC SYSTEM TO ENSURE THE SYSTEM IS DE-ENERGIZED. IT MAY BE NECESSARY TO BLEED THE SYSTEM OF REMAINING COMPRESSED AIR, THIS CAN BE PERFORMED AT THE BASE OF THE WATER SEPARATOR BOWL.</p>

10.3 Returning to Service:

1. Check the lift and the immediate area around the lift to ensure that nonessential items, tools and parts are removed and that the lift components are operationally intact.
2. Check the work area to ensure that all employees have been safely positioned or removed from the work area.
3. Notify all employees that the lockout/tagout is going to be removed and the lift is going to be restarted.
4. Remove the lockout/tagouts in the reverse order as the installation.
5. Verify the proper operation of the equipment.
6. Notify affected employees that the maintenance/service is completed and the machine is ready for operation.

10.4 Emergency Operation:

If the lift becomes inoperative in the raised position, it is best to wait until the electrical power is restored before lowering the vehicle. However, if it's critical to safety that the lift be lowered, the following steps should be taken.



WARNING: DO NOT LOOSEN OR REMOVE HYDRAULIC CONNECTIONS OR FITTINGS UNDER PRESSURE. SERIOUS INJURY OR DEATH COULD OCCUR.

NOTE: Safely performing this process requires 3 people. All personnel should stay clear of the path of the lift. All tools and other non-secured items should be removed from the surface of the runways.

1. Survey the area surrounding the lift; remove any items and personnel from area before proceeding with this procedure.
2. Perform the appropriate lockout/tag out procedure on the electrical energy.
3. Use a second person standing at a safe distance away from the lift to keep watch on the area, lift, vehicle and other personnel throughout the process. This person should signal the person performing the procedure to stop if necessary.
4. Use a caution tape or similar to barrier the area around the lift to avoid personnel from accidentally entering the area while this process is being performed.
5. Do not proceed with this procedure if you are unfamiliar with the lift or its function.

If Mechanical Locks are NOT Engaged:

1. Pull safety release lever simultaneously pressing the descent lever on the powerpack.
2. Keep a close eye on the movement of the lift and the position of the vehicle; release descent lever if any abnormal movement is detected.
3. Continue until the lift is fully lowered.
4. Once power is restored follow the lockout/tag out procedure to return the lift back into service.

If Mechanical Locks ARE Engaged:

Various methods can be used to raise the lift in order to get sufficient clearance to disengage the mechanical locks. The safest method would employ temporary electrical power to the lift using a portable power generator. Any electrical connections should be done by a licensed electrician; lockout/tag out procedures should also be employed at this time.

This process should only be performed by a trained professional. Contact customer service or a local service professional for further assistance.

11.0 TROUBLESHOOTING

PROBLEM	REASON	SOLUTION
Power Pack (Motor) not running.	Bad Fuse or Circuit breaker. Incorrect voltage to motor. Improper wiring. Power Pack up switch not functioning. Overhead Microswitch not functioning. Power Pack motor burned out.	Replace bad fuse or reset circuit breaker. Provide proper voltage to motor. Have certified electrician check wiring. Replace Power Pack up switch. Replace overhead Microswitch. Replace motor.
Power Pack (Motor) runs but lift does not go up.	Low oil level. Oil valve remains open. Pump sucking air.	Fill reservoir with proper hydraulic oil. Repair or replace oil valve. Tighten all fittings and suction lines.
Lift goes up slowly or oil coming out from filler cap.	Air in hydraulic fluid lines	Bleed hydraulic lines (Call installer).
Lift doesn't come down.	Dirt in directional valve	Call installer to clean valve. (Do not attempt to open hydraulic lines unless vehicle is secure)
Safety Dog does not engage.	Safety Dog pivot pin jammed. Air Cylinder seized	Oil or replace pin to free Safety Dog. Replace Air Cylinder.
Safety Dog does not disengage.	No air in the system	Check if air is being supplied.
Lift goes up unlevel.	Equalizing cables are loose. Floor unlevel.	Adjust equalizing cables to correct tension. Shim lift to make towers level. (Do not exceed ½" of shimming).
Lift goes up with chatter or does not fully rise.	Low oil level. Air in hydraulic fluid lines/cylinder.	Fill reservoir to correct level with proper hydraulic oil. Bleed hydraulic lines. (Call installer).
Anchor bolts do not stay tight.	Holes are too large. Incorrect concrete floor specification (Thickness and holding strength).	Relocate lift using proper size drill bit. Break existing floor and pour new pad for lift.
Noticeable Deflection of Arm or arm dragging on floor.	Lift out of plumb. Unlevel floor. Worn arm pins. Worn arm or carriage holes. Worn carriage slide blocks. Bent arm (Overloaded).	Plumb columns. Replace floor or shim columns. Replace arm pins. Replace parts. Replace side blocks. Replace arm. Also check damage to carriage.

12.0 LIFT ASSEMBLY

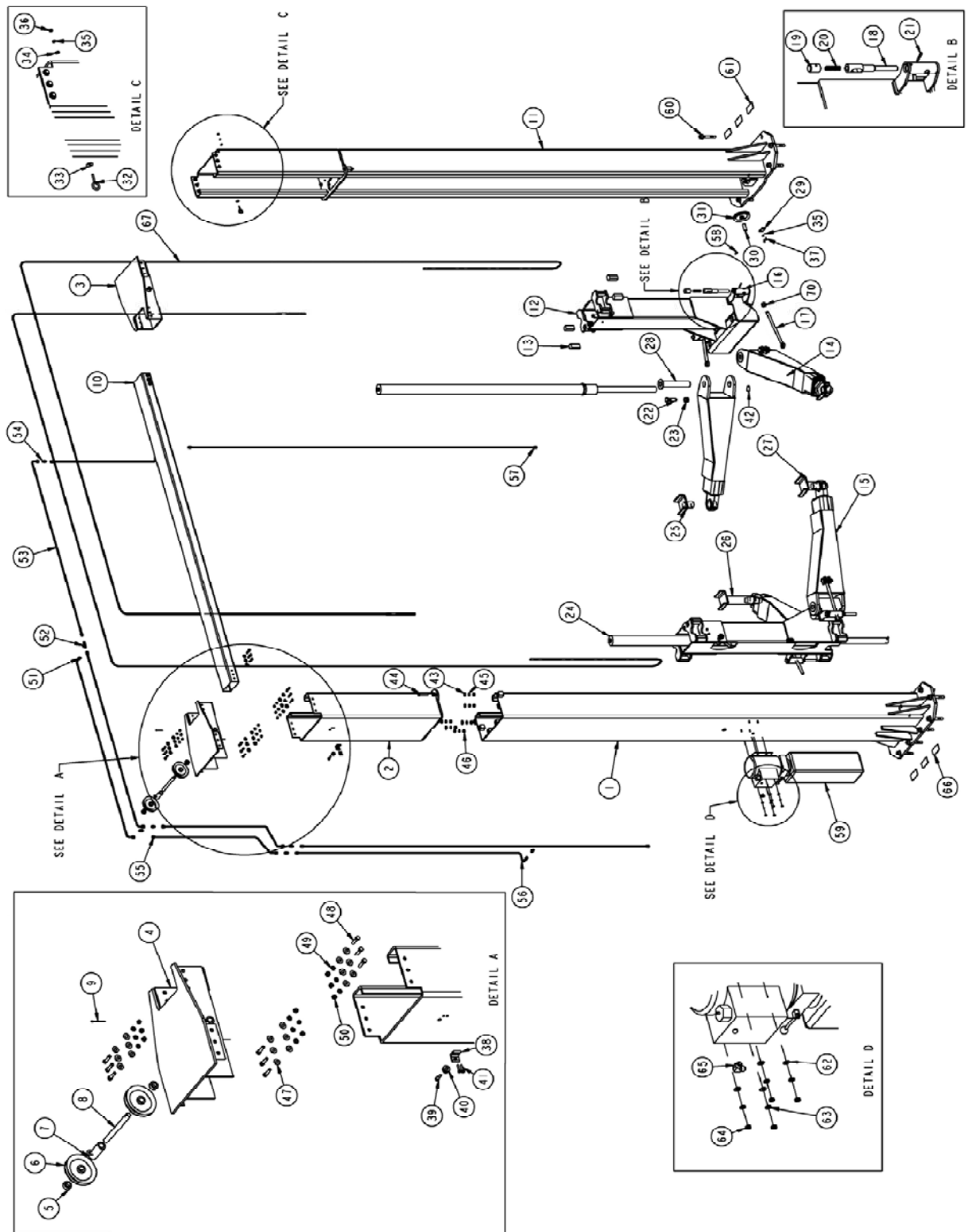

REPLACE WORN, DAMAGED OR BROKEN PARTS WITH PARTS APPROVED BY THE ORIGINAL EQUIPMENT MANUFACTURER ONLY

12.1 Lift Assembly Parts List

Item#	Part #	Description	Qty.
1	3-0946	DRIVER TOWER WELDMENT	1
2	2-2460	TOWER EXTENSION WELDMENT	2
3	2-2954	CROSSEMBER END ASS'Y	2
4	2-2955	CROSSMEMBER END WLDMT	2
5	1-4024	SHEAVE SPACER	2
6	1-2346	SHEAVE ASSEMBLY	4
7	1-4026	SHEAVE SPACER	4
8	1-4027	SHAFT OVERHEAD PULLEY	2
9	6-3157	COTTER PIN, 3/16" X 1-3/4"	2
10	2-2258	CROSSMEMBER TUBE	1
11	3-0945	IDLE TOWER WELDMENT	1
12	3-0943	CARRIAGE WELDMENT	2
13	1-2966	BEARING BLOCK	8
14	3-1125	SYMMETRIC ARM ASSEMBLY, FL/RR	2
15	3-1126	SYMMETRIC ARM ASSEMBLY, FR/RL	2
16	1-3015	ARM RESTRAINT COLLAR	4
17	2-2273	ARM RESTRAINT ROD WELDMENT	4
18	2-2274	PLUNGER WELDMENT	4
19	1-2965	ARM RESTRAINT CAP	4
20	6-3112	ARM LOCK SPRING	4
21	6-3127	ROLL PIN 1/4" DIA. 1 3/4" LG.	4
22	6-1101	3/4"-10 X 3" LG. HEX HD. BOLT GR5.	4
23	6-3123	LOCKNUT 3/4"-10 UNC NYLOCK	5
24	2-2518	HYDRAULIC CYLINDER	2
25	2-2283	PAD ADAPTER	2
26	2-2285	ARM PAD EXTENSION ASS'Y 10 INCH	1
27	2-2284	ARM PAD EXTENSION ASS'Y 5 INCH	1
28	1-2989	ARM PIN	4
29	1-2976	KEEPER PLATE	2
30	1-2975	SHEAVE PIN	2
31	1-3019	SHEAVE, 3/8" ROPE 4-1/2" PD	2
32	6-0904	BENT EYE BOLT 1/4"-20 UNC X 1 1/2" LG.	1
33	6-0626	1/4" ID. FENDEWASHER	1
34	6-0060	Flat Washer, 1/4" I.D.	1
35	6-0056	Lock Washer, 1/4" I.D.	7
36	6-0032	Hex Nut, 1/4"-20UNC	3
37	6-0126	Hex HD. Bolt, 1/4"-20UNC x 1/2" LG.	4
38	1-3216	BRACKET, SAFETY PULLEY	1
39	6-0069	Shoulder Bolt, 3/8DIA. X 5/8 LG.	1
40	1-1116	SAFETY CABLE PULLEY	1
41	6-0008	Hex HD. Bolt, 1/4"-20UNC x 1" LG.	2
42	6-3168	RETAINING RING 1 3/4"	4
43	6-0248	Flat Washer, 1/2 ID SAE	24
44	6-1381	Hex HD. bolt 1/2"-13 UNC x 3" LG.	12
45	6-0059	Lock Washer, 1/2"	12

46	6-0035	NUT, 1/2-13 UNC, HEX	12
47	6-0625	3/8" ID. USS FLUT PLTD. WASHER	48
48	6-0203	HEX BOLT 3/8 UNC X 1-1/2 LG, GR5	24
49	6-0058	LOCK WASHER, 3/8"	24
50	6-0034	HEX NUT, 3/8" NC	24
51	6-3114	HYDRAULIC TUBING	1
52	6-1372	3/8" UNION TEE M JIC	1
53	6-3152	HYDRAULIC TUBING	2
54	6-0286	ADAPTOR 3/8" M JIC - 3/8" M JIC	7
55	6-3151	HYDRAULIC TUBING	3
56	6-3149	HYDRAULIC TUBING	1
57	6-3153	HYDRAULIC TUBING	2
58	6-3285	SET SCREW 3/8" DIA. - 1" LG	2
59	6-3150	Power Pack, 208-230 V, 1 PH	1
60	6-1379	Wedge Anchor 3/4" x 5 1/2" LG. (c/w Washer & Nut)	16
61	6-0739	1/16" THK. SHIM (PLASTIC)	3
62	6-0295	FLAT WASHER, 5/16" I.D.	4
63	6-0674	LOCK WASHER, 5/16 I.D.	4
64	6-0294	HEX NUT, 5/16-18 UNC	4
65	6-0804	Elbow 90 deg., 9/16" SAE M-3/8" JIC M	1
66	6-0740	1/8" THK. SHIM (PLASTIC)	3
67	6-3118	EQUALIZING CABLE 464" LG	2
68	1-3517	CABLE RETAINER PIN	2
69	6-3613	1/4" RETAINING RING	4
70	6-3123	3/4"-10 UNCLOCK NUT,NYLON	4

13.0 HYDRAULIC SYSTEM

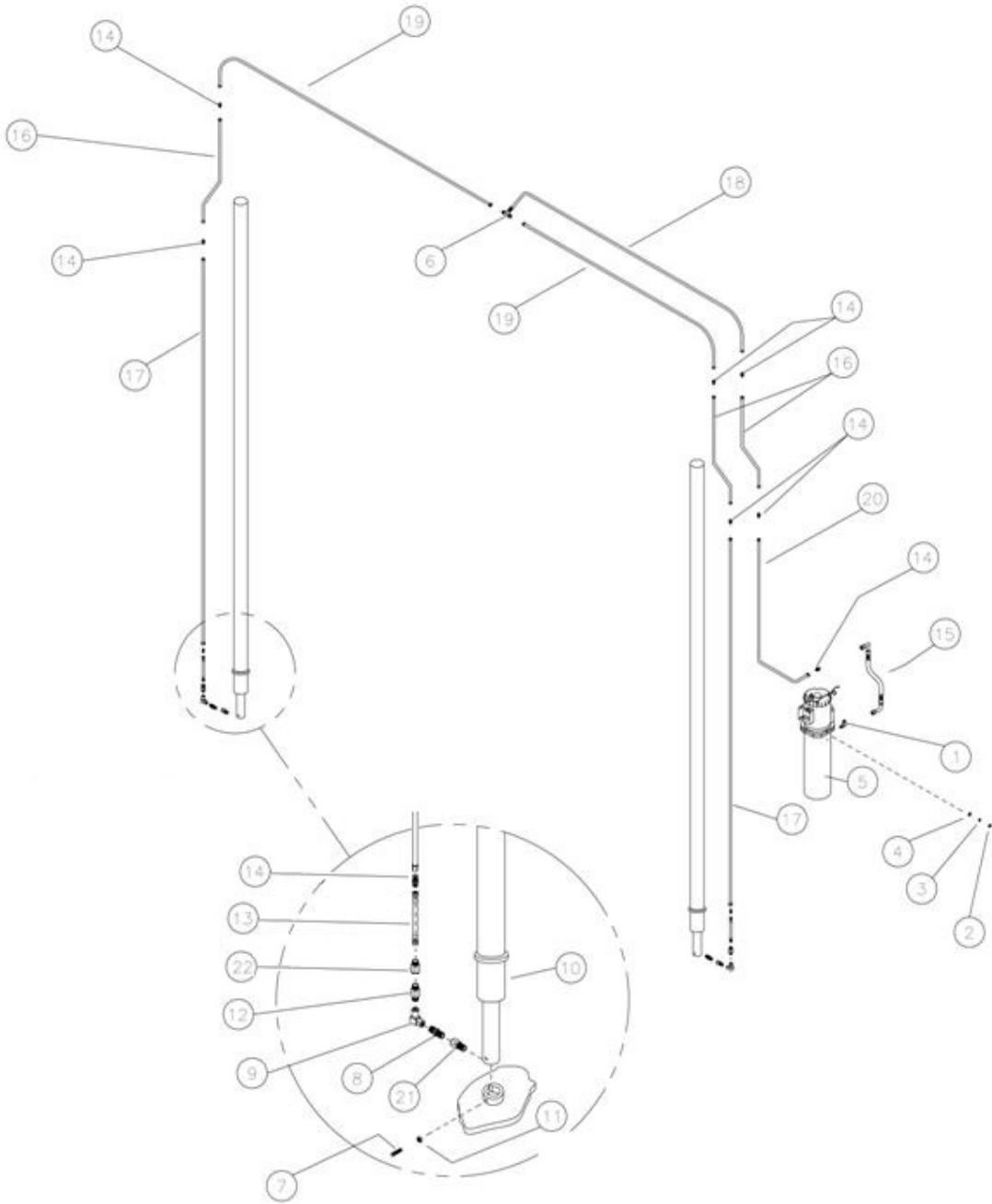

13.1 Hydraulic System Parts List

Item	Part #	Description	Qty
1	6-0804	ELBOW 90 DEG 9/16 SAE M-3/8 JIC M	1
2	6-0294	HEX NUT 5/16"-18 UNC	4
3	6-0674	LOCKWASHER 5/16" I.D	4
4	6-0295	WASHER FLAT 5/16" ID SAE	4
5	6-3150	POWER UNIT	1
6	6-1372	3/8" UNION TEE M JIC	2
7	6-3061	SET SCREW 3/8"-16 1"LG	2
8	6-3876	ADAPTOR 3/8" M NPT – 3/8" M NPT	2
9	6-0006	COUPLING 3/8" F NPT 90 DEG FORGED	2
10	2-2518	HYDRAULIC CYLINDER	2
11	6-3119	HEX NUT 3/8"-16 UNC	11
12	6-0270	ADAPTER, 1/4" M NPT - 3/8" M NPT	2
13	2-2136	HYDRAULIC HOSE ASSEMBLY	2
14	6-0286	ADAPTOR 3/8" M JIC – 3/8" M JIC	2
15	6-3148	HYDRAULIC HOSE ASSEMBLY	1
16	6-3151	HYDRAULIC TUBING ASSEMBLY	3
17	6-3153	HYDRAULIC TUBING ASSEMBLY	2
18	6-3114	HYDRAULIC TUBING ASSEMBLY	1
19	6-3152	HYDRAULIC TUBING ASSEMBLY	2
20	6-3149	HYDRAULIC TUBING ASSEMBLY	1
21	6-3205	1/4" NPT M - 3/8" NPT F ADAPTOR	2
22	6-4151	FLOW CONTROL	2
*	6-3975	SEAL KIT FOR CYLINDER 22518	

13.2 Power Pack Parts List

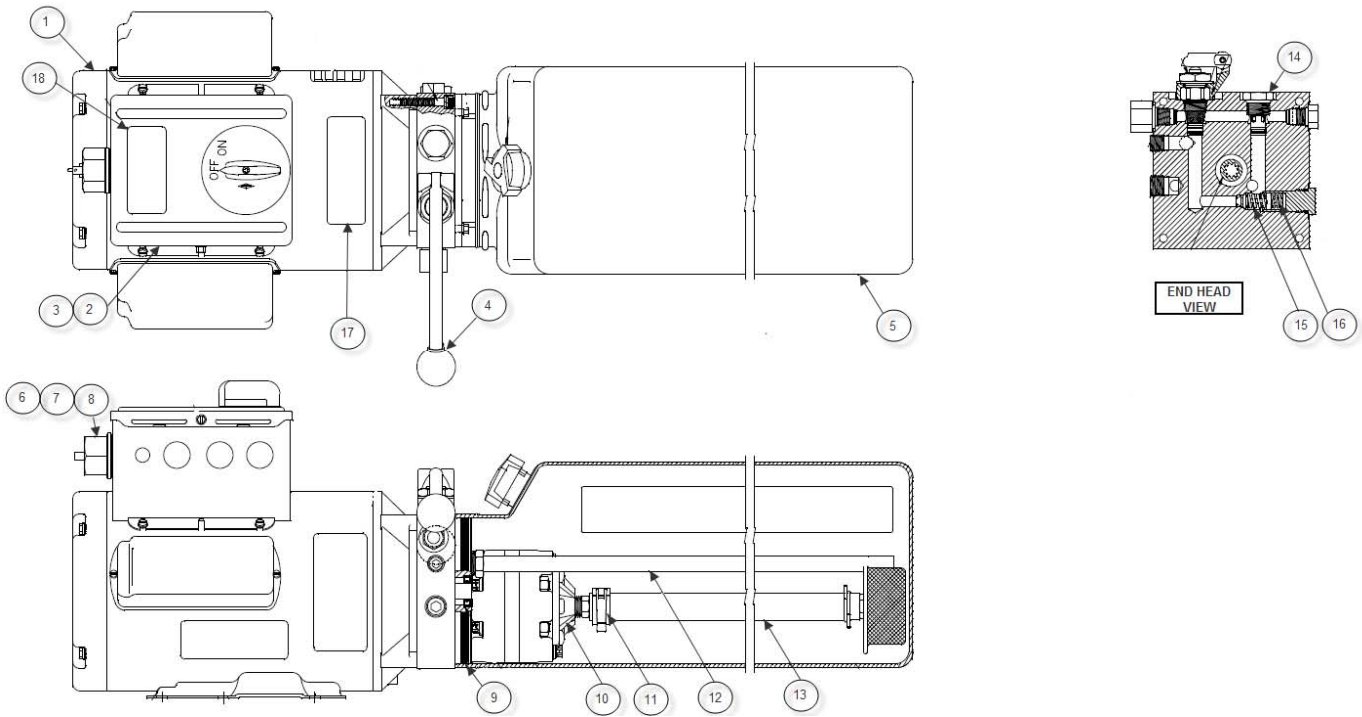

Item	Part #	Description	Qty
1	6-4171	MOTOR, ELEC. 230V / 1 PH / 60HZ	1
2	6-4172	AC WIRING ASSEMBLY	1
3	6-4173	WIRE ASSY, 14AWG GREEN/YELLOW, 7"	1
4	6-4174	BRACKET-HANDLE RELEASE ASSEMBLY	1
5	6-4175	PLASTIC TANK 4 GALLON	1
6	6-4176	ELECTRIC ASSEMBLY LIMIT SWITCH	1
7	6-4177	SWITCH MOMENTARY, ON, 25A	1
8	6-4186	WIRE ASSY, 14AWG BLACK, 10"	1
9	6-1087	VALVE CARTRIDGE RELEASE MANUAL	1
10	6-2165	COVER ASSY SUCTION	1
11	6-4179	PLUMBING CLAMP HOSE INLET	1
12	6-4180	RETURN HOSE	1
13	6-3706	PLUMBING ASSY INLET	1
14	6-4181	VALVE, CARTRIDGE CHECK	1
15	6-4182	RELIEF ASSEMBLY FIXED	1
16	6-4183	COMPRESSION TUBE SLEEVE	1
17	6-2136	LABEL, INSTALLATION AUTOHOIST	1
18	6-4182	DECAL, INSTALLATION AUTO-HOIST	1

14.0 SAFETY SYSTEM

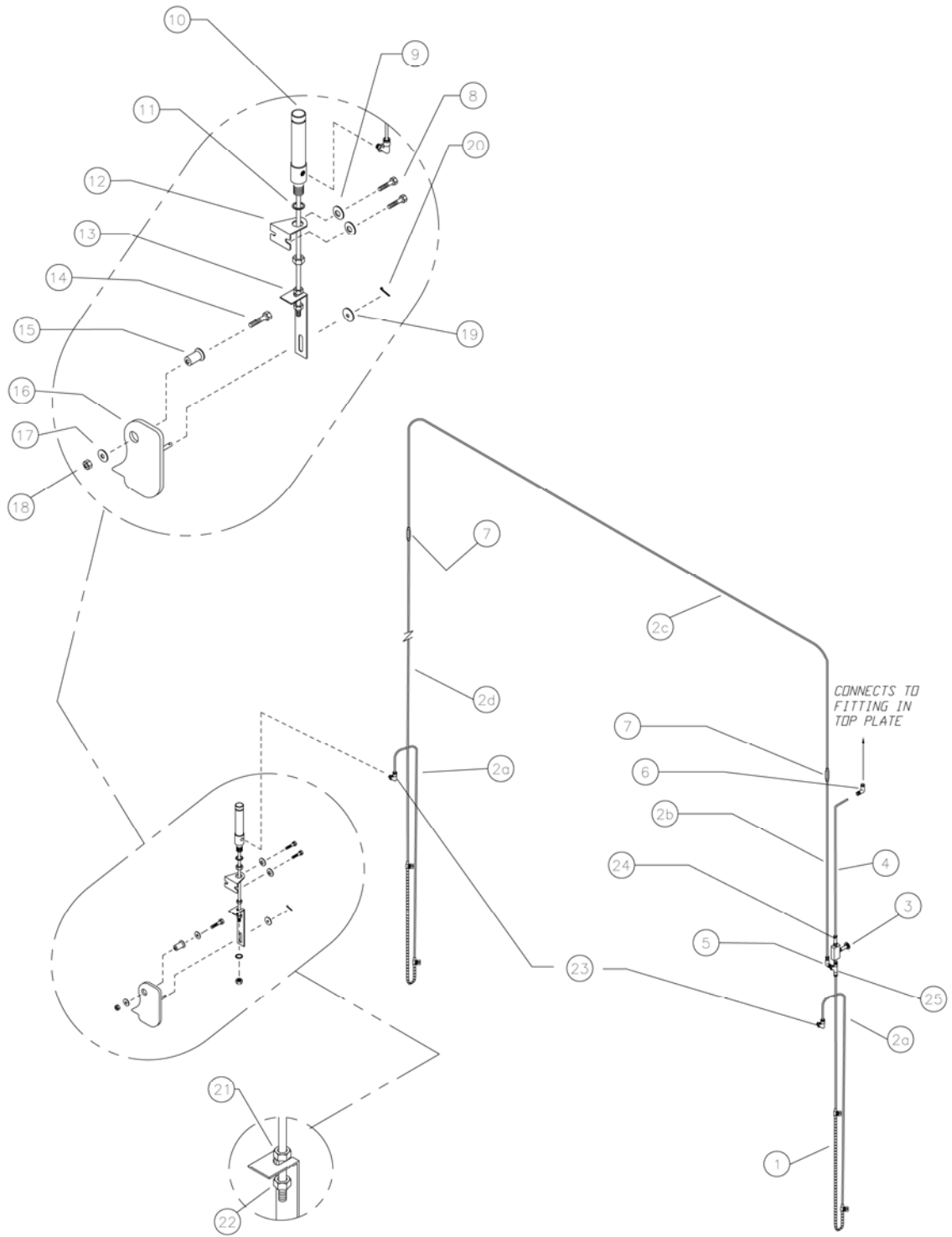

14.1 Safety System Parts List

Item	Part #	Description	Qty
1	1-3026	MICRO CABLE CARRIER ASSEMBLY	2
2a	80307	PNEUMATIC TUBING 4mm 127" LG	1
b	"	PNEUMATIC TUBING 4mm 94 3/4" LG	1
c	"	PNEUMATIC TUBING 4mm 222" LG	1
d	"	PNEUMATIC TUBING 4mm 225" LG	1
3	6-3136	AIR VALVE	1
4	8-0141	PNEUMATIC TUBING 1/4" DIA 100" LG	1
5	6-3131	PLUG IN ELBOW 5/32" – 5/32"	2
6	6-3135	MALE ELBOW 1/4" – 1/4" NPT	1
7	6-3133	HOSE TO HOSE COUPLING 5/32" – 5/32"	2
8	6-0027	HEX BOLT 1/4" –20 UNC 1 1/4" LG. PLT	4
9	6-0295	FLAT WASHER 3/8"	4
10	6-3111	AIR CYLINDER 3/4 BX(1.00) STROKE	2
11	6-0663	LOCKWASHER INTERNAL TOOTH 5/8	2
12	6-3110	AIR CYLINDER MTG. BRKT 2 POST AIR RELEASE	2
13	2-2249	SAFETY RELEASE BRKT 2 POST AIR RELEASE	2
14	6-1643	HEX BOLT 7/8"-9 x 3 1/2" LG	2
15	1-2996	SAFETY BLOCK SPACER	2
16	1-3022	SAFETY DOG ASSY & WELDMENT	2
17	6-0725	WASHER FLAT 7/8" I.D	2
18	6-3124	LOCKNUT 7/8"-9 UNC NYLON	2
19	6-0625	WASHER 3/8"	2
20	6-3145	COTTER PIN 3/32" x 1"	2
21	6-3144	HEX JAM NUT 1/4"-28 UNF	4
22	6-1563	LOCKNUT 1/4"-28 NYLON UNF	2
23	6-3129	MALE ELBOW 5/32" –1/8" NPT	2
24	6-3130	MALE CONNECTOR 1/4" - 1/8" NPT	1
25	6-3132	MALE RUN'G TEE 5/32" – 5/32" – 1/8"	1

15.0 AVAILABLE ACCESSORIES



Low Lift Adapters (1-3/8" thread or 2" thread)



Foam Door Protector Kit



**Air/Electric Service Station for
2-Post & 4-Post
(90-110 psi – 110 Volts Required)**

Contact supplier for availability and part numbers.